

ADIDAS ESSENTIAL AB BENCH

Assembly & User Instructions - Please keep for future reference

ADBE/10331

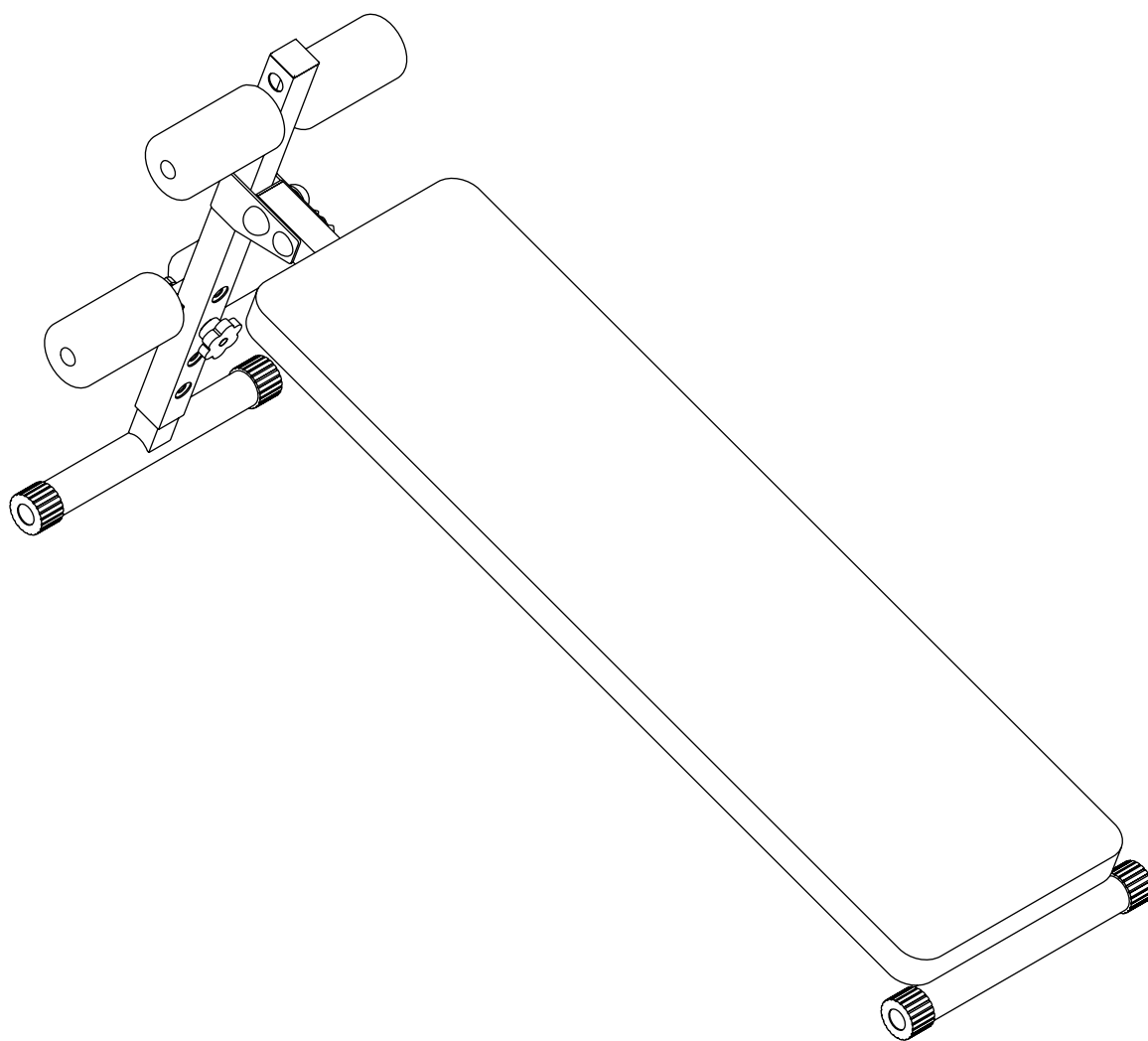

Important – Please read these instructions fully before assembly or using

Components - Parts



Please check you have all the parts listed below

Note: Some of the smaller components may be pre-fitted to larger components. Please check carefully before contacting Argos regarding any missing components.

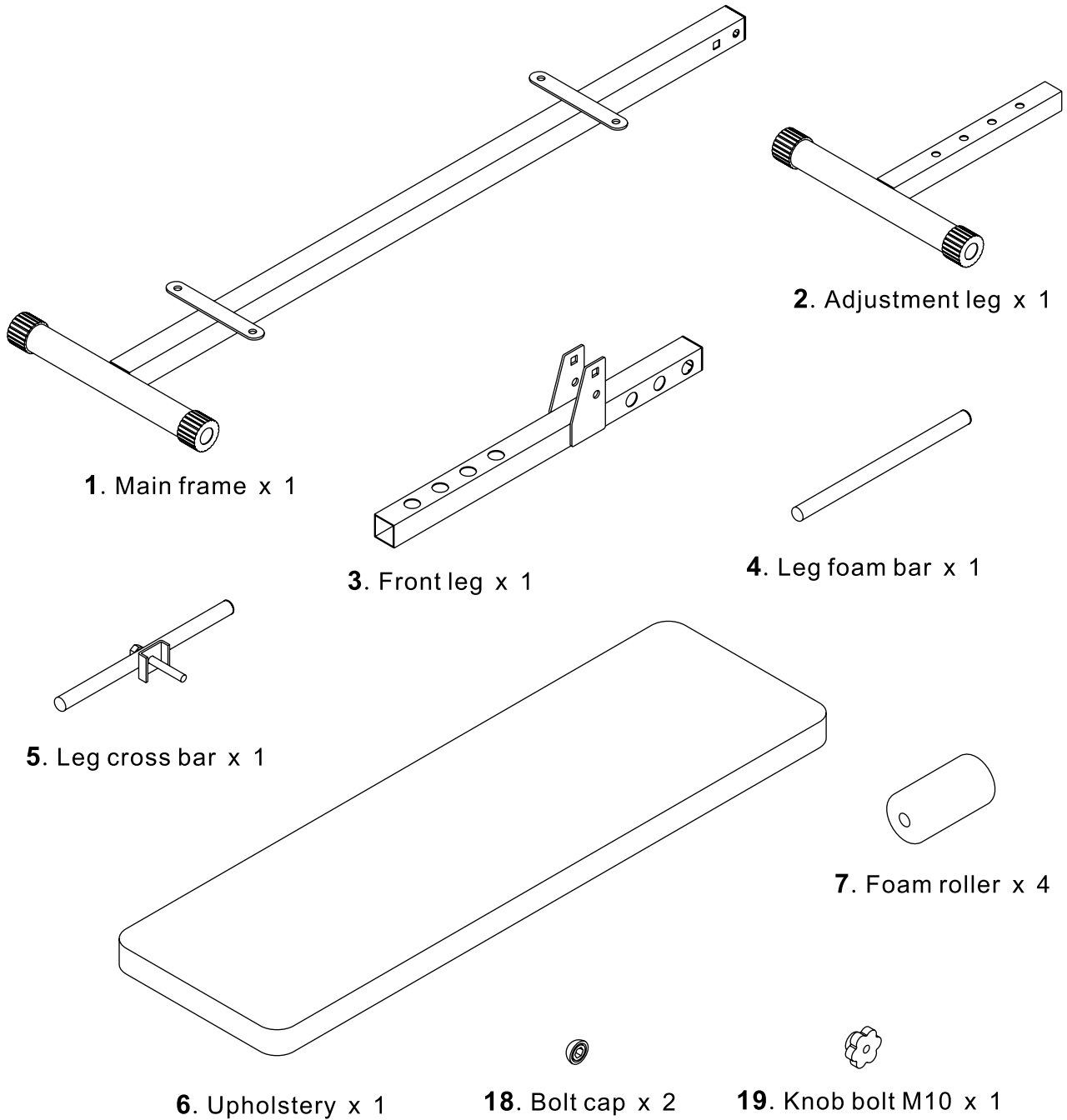







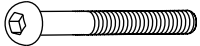

Components - Fixings

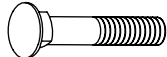

Please check you have all the fixings listed below

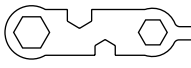
Note: Some of the fixings are pre-fitted to the larger components. Please check carefully before contacting Argos regarding any missing fixings.

<p>8 </p> <p>M10 x 55mm Bolt x 1</p>	<p>9 </p> <p>M6 x 15mm Screw x 4</p>	<p>10 </p> <p>M10 x 55mm Carriage bolt x 1</p>
<p>11 </p> <p>M10 Nylon locknut x 1</p>	<p>12 </p> <p>M10 Wing nut x 1</p>	<p>13 </p> <p>M10 Washer x 2</p>
<p>14 </p> <p>M6 Washer x 4</p>	<p></p> <p>Multi hex tool x 1</p>	<p></p> <p>Hex key tool x 1</p>

Ruler - Use this ruler to help correctly identify the hardware

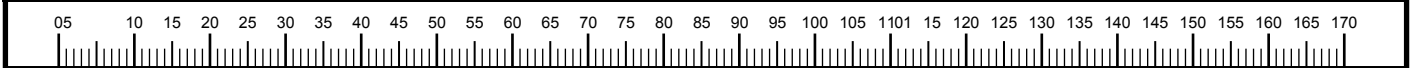

Assembly Instructions



Step 1

(2) (3) (5) bolt M10 (19).

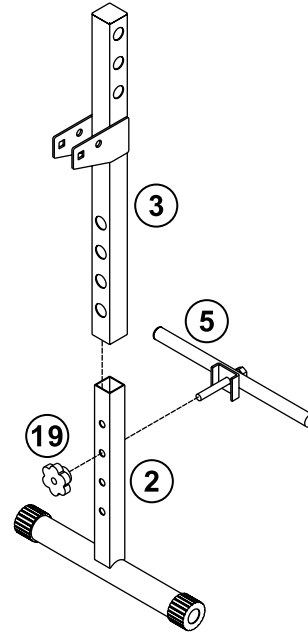

Step 2

Leg (3) (1) M10 x 55mm Bolt (8) M10 Washers (13) M10 Nylon locknut (11). (18) 55mm Bolt (8) Nylon locknut (11). M10 x 55mm Carriage bolt (10) (3) (1) (12).

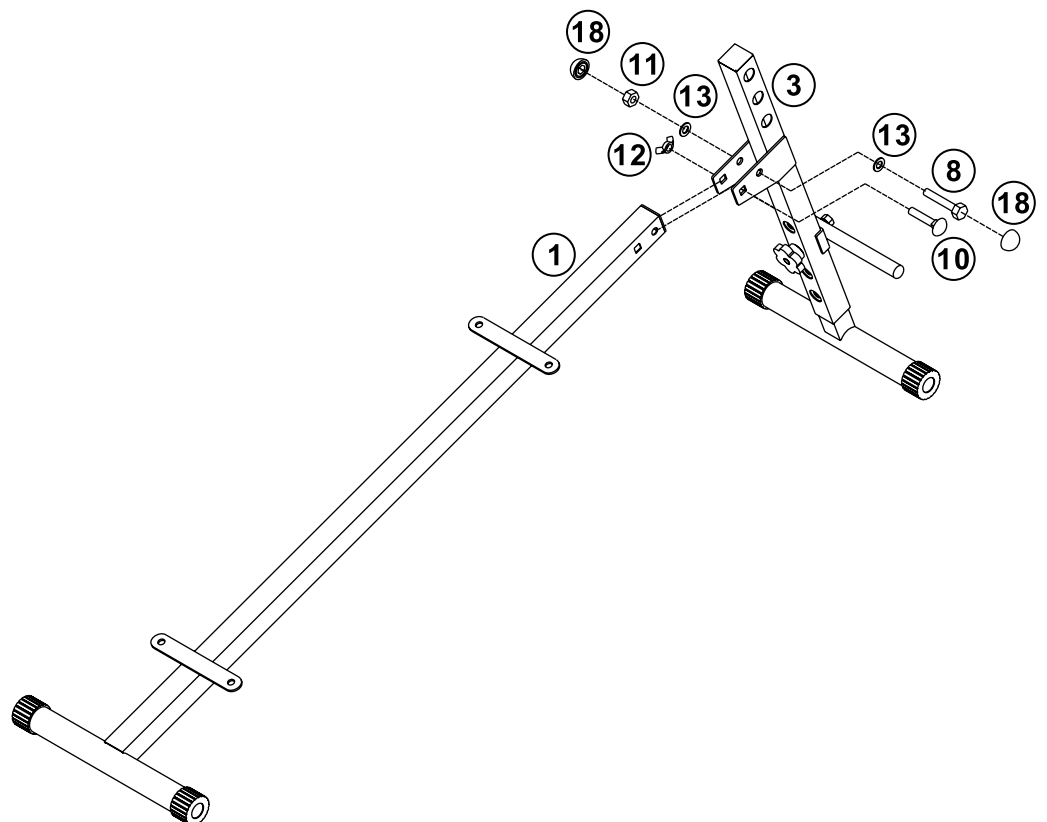

Assembly Instructions



Step 3

(6) (1) M6 x 15mm
Screws (9) and M6
Washers (14).

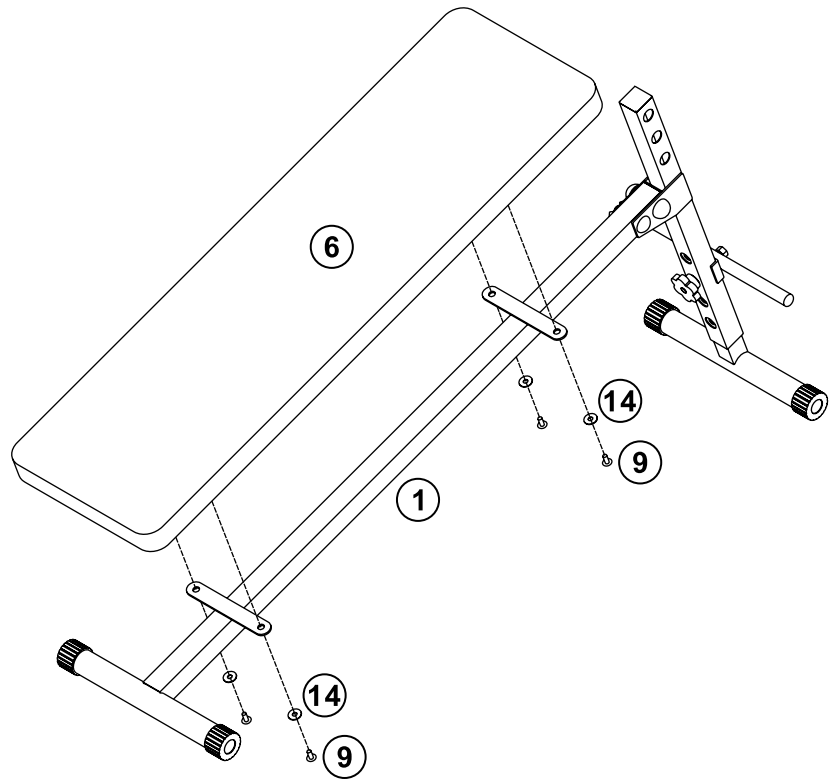

Step 4

(4) (3) (7) (4) (5).

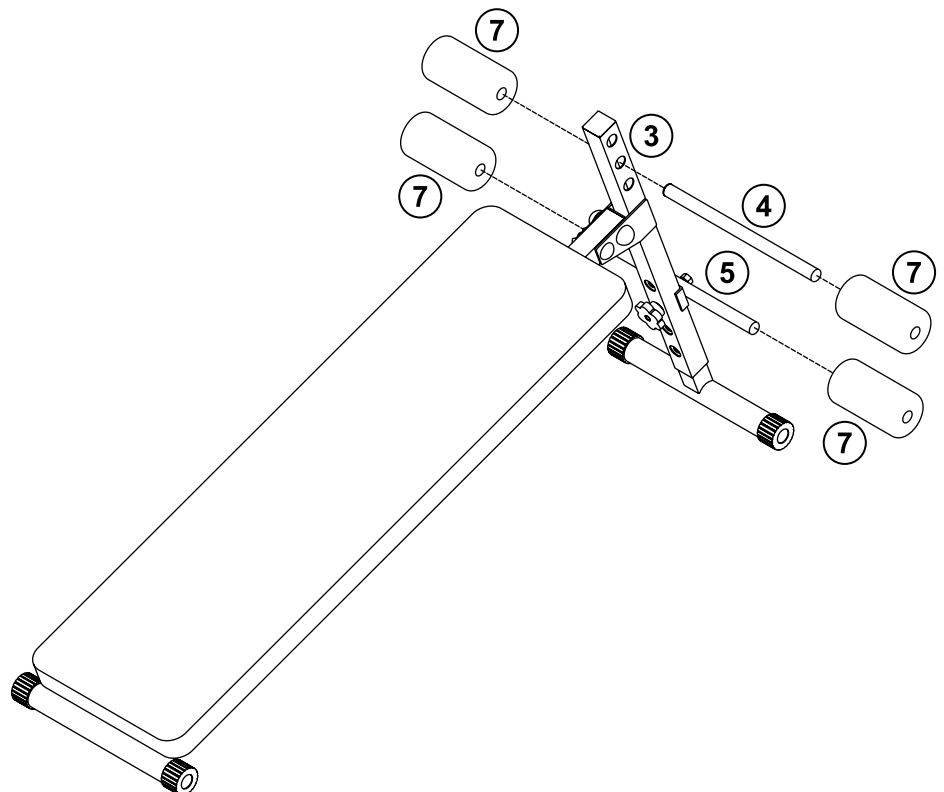

User Information



Decline Adjustment

Remove Knob bolt M10 (19) and Leg cross bar (5). Slide adjustment leg (2) up or down until bench is at desired height. Refit Leg crossbar (5) and Knob bolt M10 (19) ensuring bolt passes through both (2) & (3).

Note: Top foam roller height can also be adjusted by removing 1 foam roller and repositioning the tube.

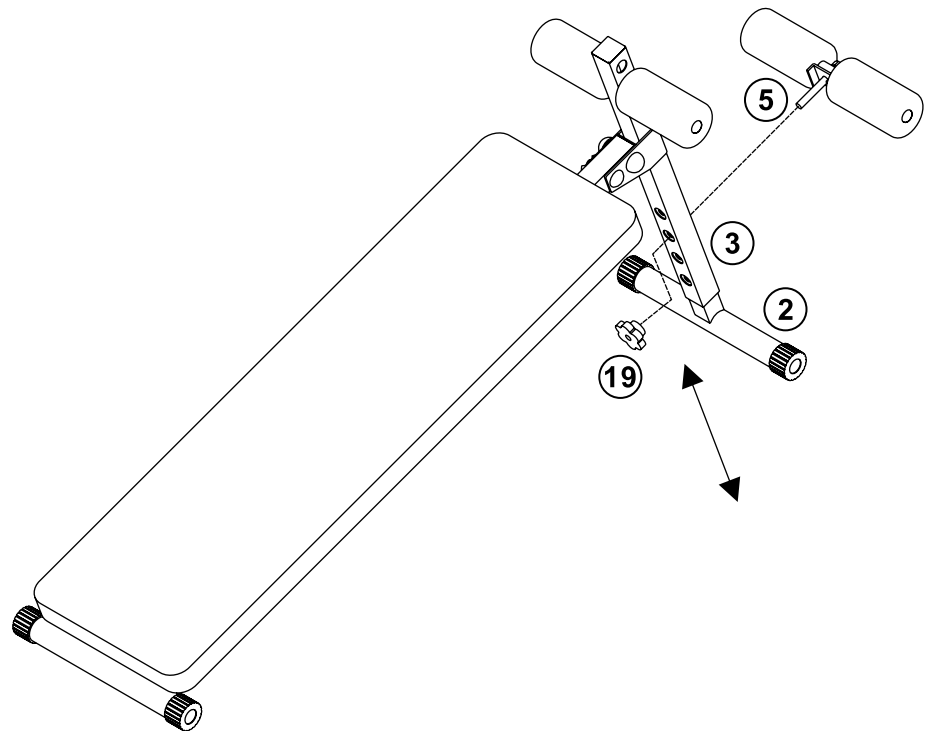

Fold for Storage

Remove Wing nut (12) and bolt (10). Rotate front leg backwards until touches main tube. Refit wing nut and bolt for storage.

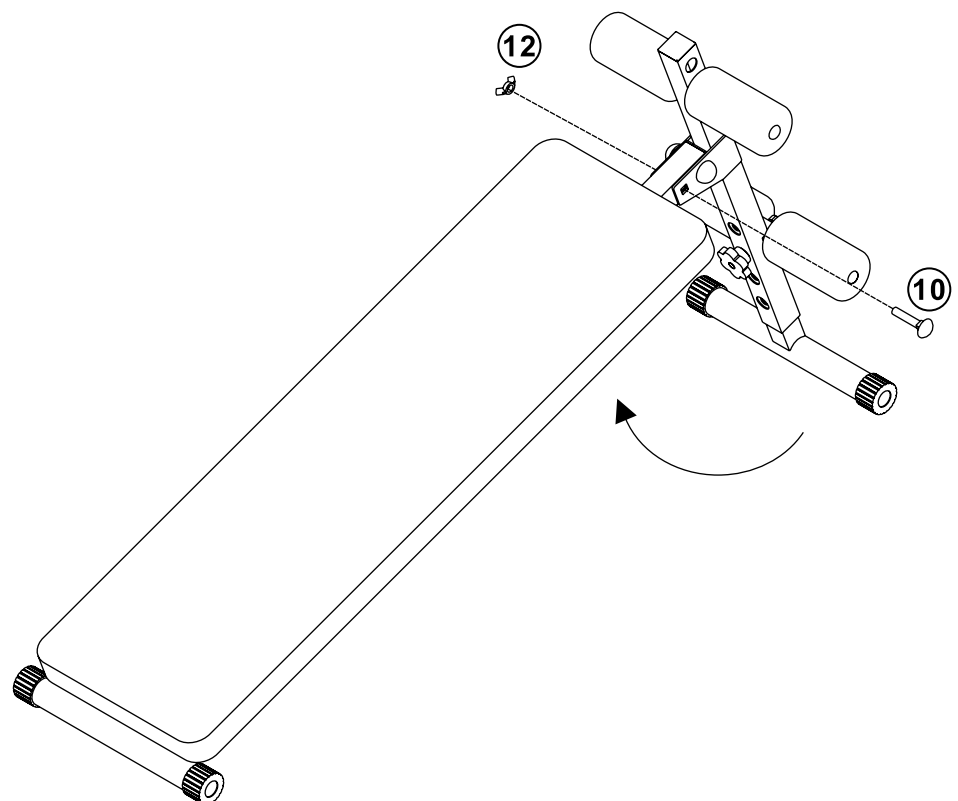

Exploded Parts Diagram

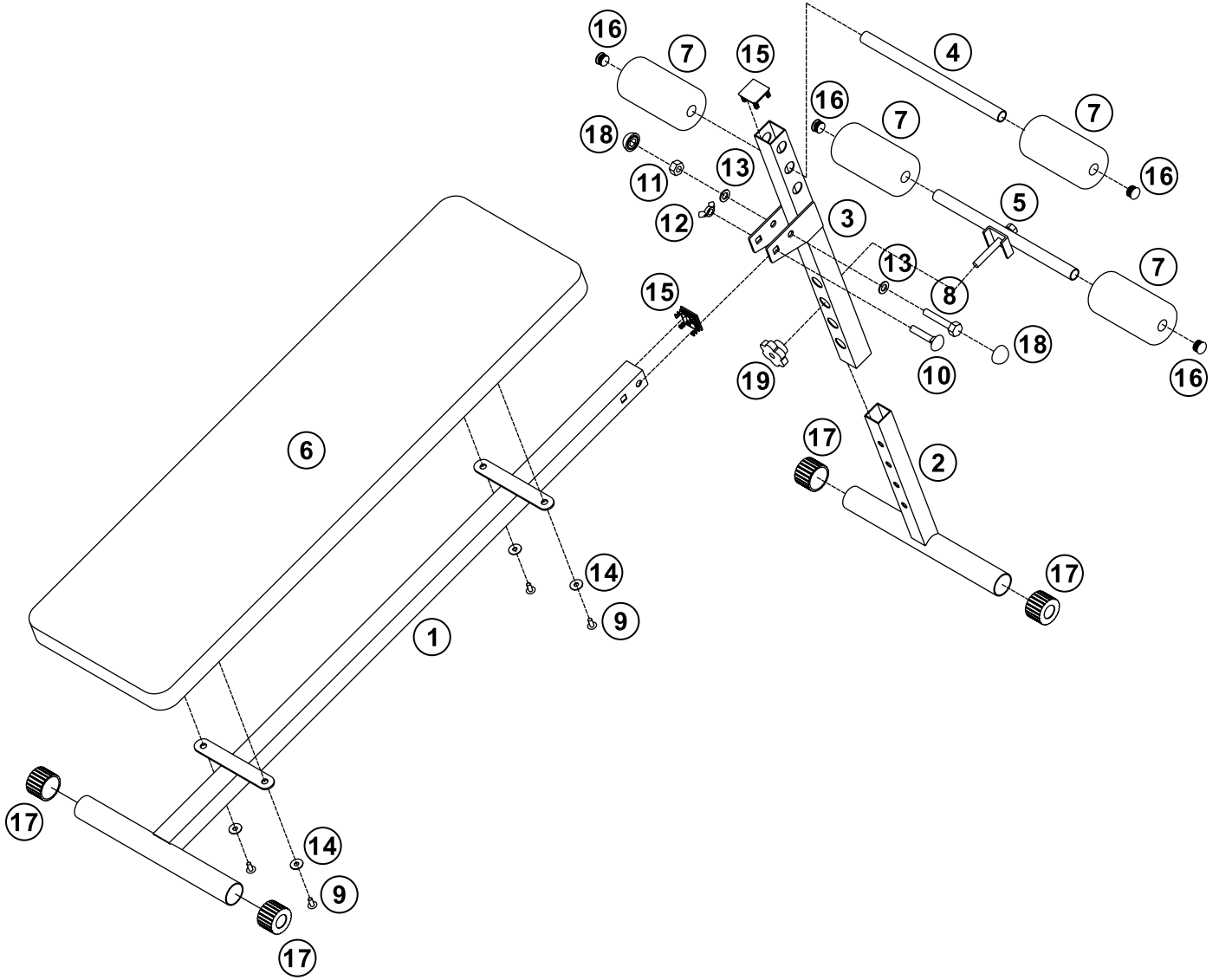

Exploded Parts Diagram List



Part	Description	Qty
1	Main frame	1
2	Adjustment leg	1
3	Front leg	1
4	Leg foam bar	1
5	Leg cross bar	1
6	Upholstery	1
7	Foam roller	4
8	M10 x 55mm Bolt	1
9	M6 x 15mm Screw	4
10	M10 x 55mm Carriage bolt	1
11	M10 Nylon locknut	1
12	M10 Wing nut	1
13	M10 Washer	2
14	M6 Washer	4
15	35mm Square inner cap	2
16	19mm Round inner cap	4
17	38mm Round external end cap	4
18	Bolt cap	2
19	Knob bolt M10	1

Guarantee



Product Guarantee

This product is guaranteed against manufacturing defects for a period of



This product is guaranteed for twelve months from the date of original purchase. Any defect that arises due to faulty materials or workmanship will either be replaced, refunded or repaired free of charge where possible during this period by the dealer from whom you purchased the unit.

The guarantee is subject to the following provisions:

- The guarantee does not cover accidental damage, misuse, cabinet parts, knobs or consumable items.
- The product must be correctly installed and operated in accordance with the instructions contained in this manual.
- It must be used solely for domestic purpose.
- The guarantee will be rendered invalid if the product is re-sold or has been damaged by inexpert repair.
- Specifications are subject to change without notice.
- The manufacturer disclaims any liability for the incidental or consequential damages.
- The guarantee is in addition to, and does not diminish your statutory or legal rights.

Email: Techsupport@RFEinternational.com.

Guarantor: RFE Europa Ltd
8 Clarendon Drive
Wymbush, Milton Keynes
MK8 8ED, UK

用户信息



斜躺调节

拆下旋钮螺栓 M10 (19) 和腿横拉杆 (5)。向上或向下滑动 (2) 调节腿直到训练椅达到所需的高度为止。重新装好腿横拉杆 (5) 和旋钮螺栓 M10 (19)，确保螺栓穿过 (2) 和 (3)。

注：另外，拆下 1 根泡沫轴并改变管的位置，也可对顶部泡沫轴的高度进行调节。

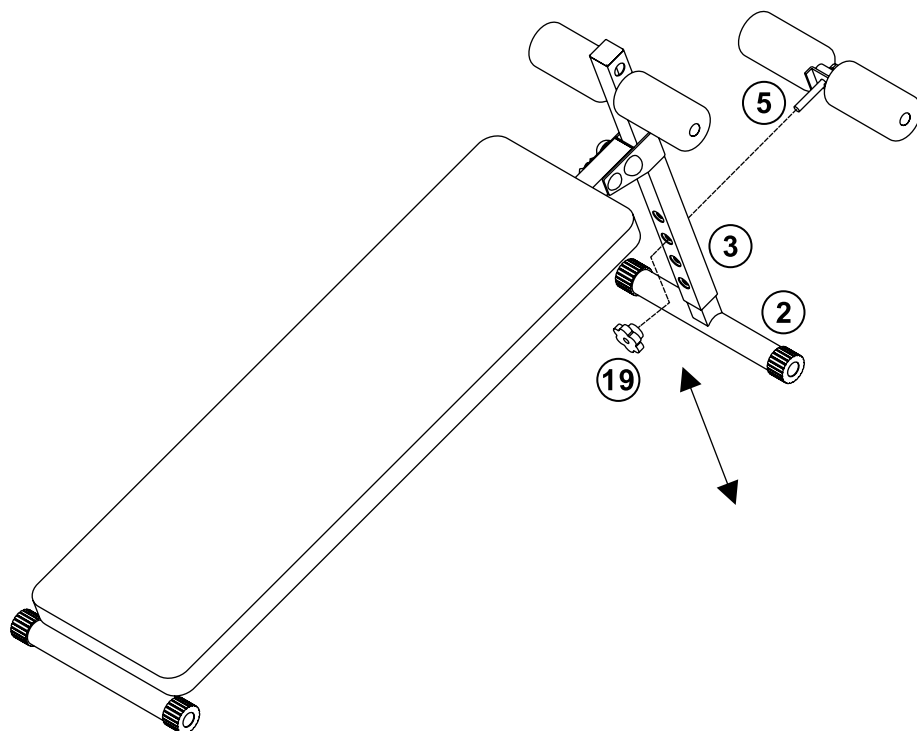

折叠存放

拆下蝶形螺母 (12) 和螺栓 (10)。向后转动前腿，直到触及主管为止。重新装好蝶形螺母和螺栓，便可存放。

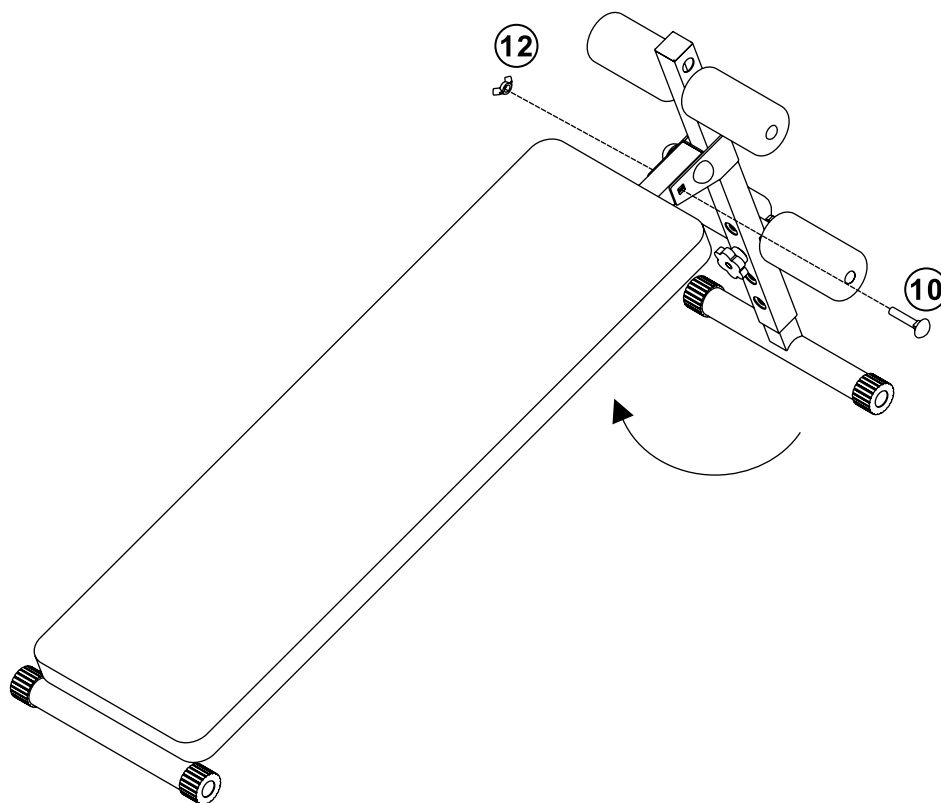

零件分解图

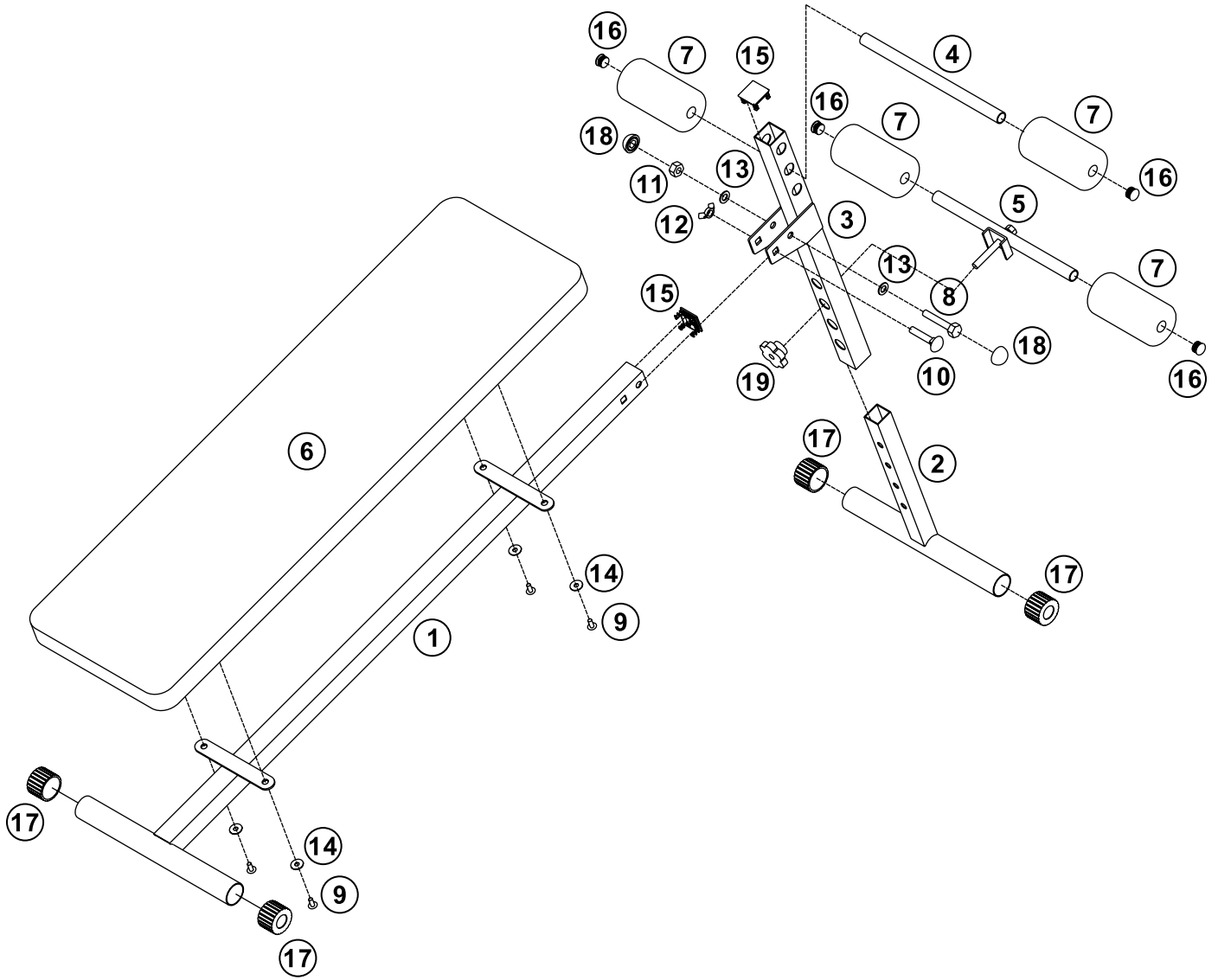

零件分解图一览表



零件	名称	数量
1	主架	1
2	调节腿	1
3	前腿	1
4	泡沫装配管	1
5	腿横拉杆	1
6	蒙皮	1
7	泡沫轴	4
8	M10 x 55 毫米螺栓	1
9	M6 x 15 毫米螺钉	4
10	M10 x 55 毫米机架螺栓	1
11	M10 尼龙防松螺母	1
12	M10 蝶形螺母	1
13	M10 垫片	2
14	M6 垫片	4
15	35 毫米方内帽	2
16	19 毫米圆内帽	4
17	38 毫米圆外端帽	4
18	螺栓帽	2
19	旋钮螺栓 M10	1



产品质保

本产品享受制造缺陷质保，期限为



本产品享受自购买日期起为期十二个月的质保。在此期限内，因材料或工艺不善而致的任何缺陷将由您从其购买本装置的经销商酌情予以免费更换、退款或修理。

本质保以以下各项规定为准：

- 本质保不含盖意外损坏、误用、柜体零件、旋钮或消耗品。
- 本产品务必根据本手册所含的说明进行安装与操作。
- 其务必仅供家用。
- 如产品转售或因非专业维修而损坏，将致使本质保失效。
- 规格可能有所更改，恕不另行通知。
- 制造商不承担任何意外或连带损失责任。
- 本质保不仅不会限制您的法定或合法权利，而且是对此的补充。

电子邮件： Techsupport@RFEinternational.com。

质保商：RFE Europa Ltd
8 Clarendon Drive
Wymbush, Milton Keynes
MK8 8ED, UK

Brugeroplysninger



Skråjustering

Fjern håndtagsbolt M10 (19) og bentværstangen (5). Skub justeringsbenet (2) op eller ned, til bænken har den ønskede højde. Genmonter bentværstangen (5) og håndtagsbolt M10 (19), mens det tilsikres, at bolten går gennem både (2) og (3).

Note: Højden på den øverste skumrulle kan også justeres ved at fjerne 1 skumrulle og flytte røret.

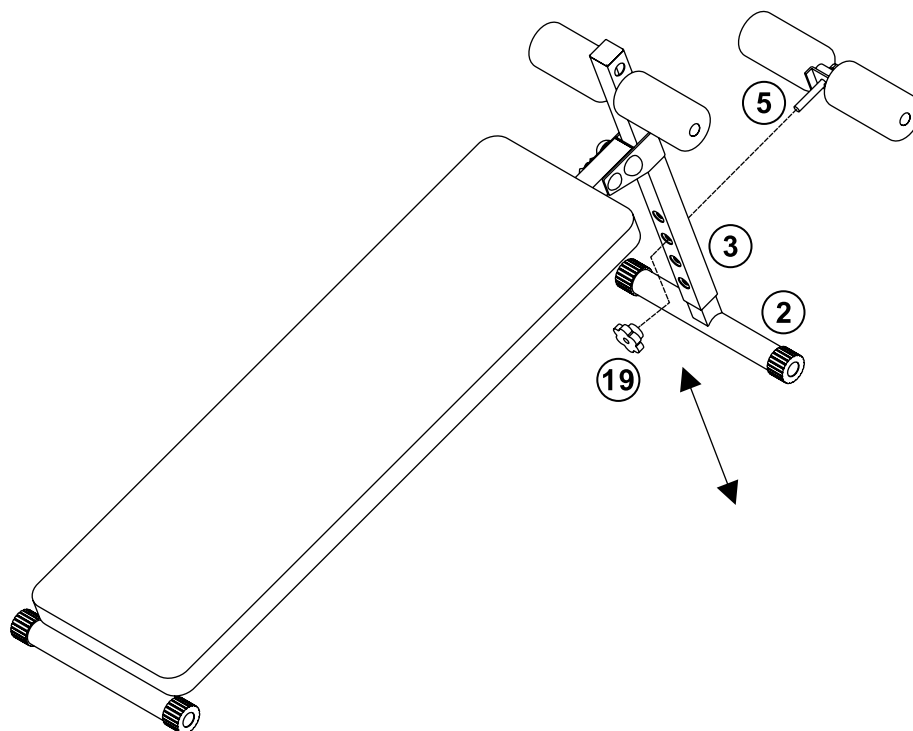

Fold sammen til opbevaring

Fjern vingemøtrikken (12) og bolt (10). Drej det forreste ben bagud, til det kommer i kontakt med det primære rør. Genmonter vingemøtrikken og bolt (10) til opbevaring.

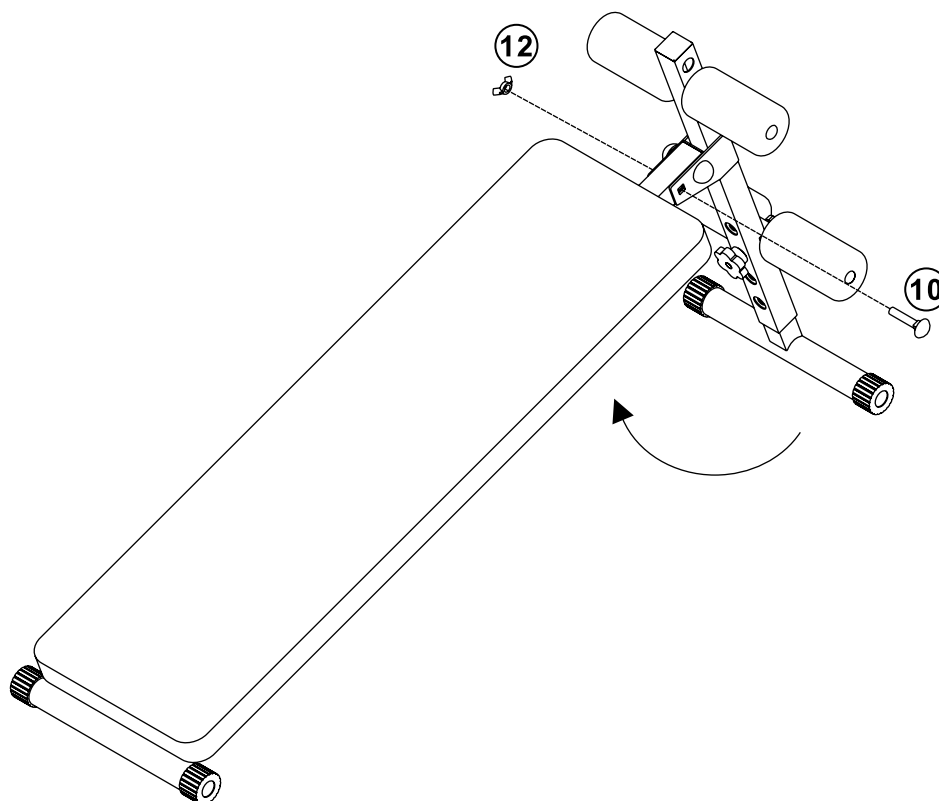

Ekspllosionstegning over dele

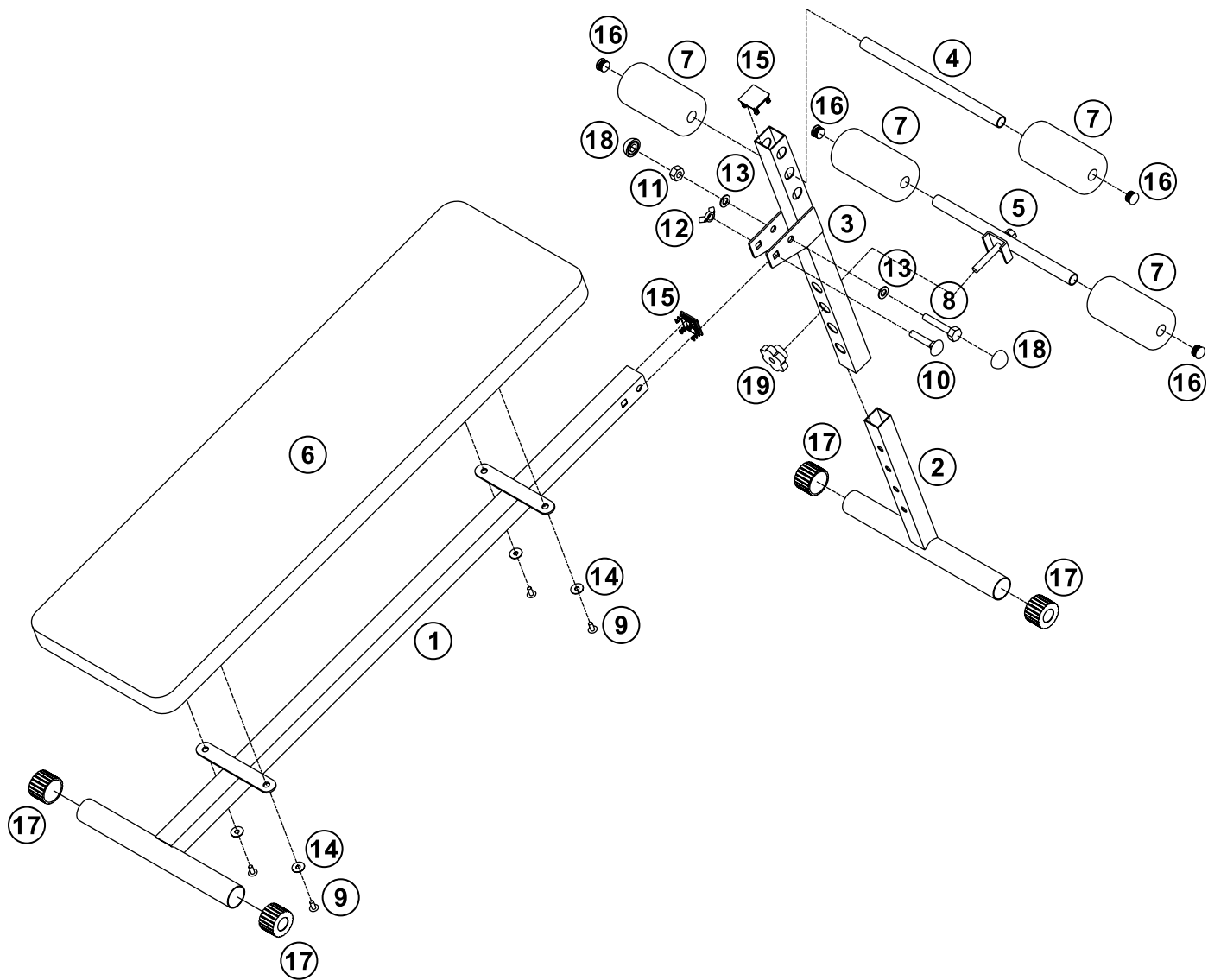

Ekspllosionstegning over dele



Del	Beskrivelse	Ant.
1	Justeringsben	1
2	Forreste ben	1
3	Benskumstang	1
4	Bentværstang	1
5	Leje	1
6	Skumrulle	1
7	M10 x 55 mm bolt	4
8	M6 x 15 mm skrue	1
9	M10 x 55 mm bræddebolt	4
10	M10 nylonkontramøtrik	1
11	M10 vingemøtrik	1
12	M10 spændeskive	1
13	M6 spændeskive	2
14	35 mm firkantet, indvendig prop	4
15	19 mm rund, indvendig prop	2
16	38 mm rund, udvendig slutmuffe	4
17	Bolthætte	4
18	Håndtagsbolt M10	2
19	Knob bolt M10	1



Produktgaranti

Dette produkt er garanteret mod produktionsfejl i en periode på



Dette produkt er garanteret i tolv måneder fra den originale købsdato. Enhver fejl, der skyldes defekte materialer eller håndværk, vil, hvor det er muligt, enten blive ombyttet, refunderet eller repareret uden beregning i løbet af denne periode af forhandleren, hvorfra du købte enheden.

Garantien er underlagt følgende betingelser:

- Garantien dækker ikke utilsigtet skade, misbrug, kabinetdele, håndtag eller forbrugsvarer.
- Produktet skal være korrekt installeret og bruges i overensstemmelse med anvisningerne i denne manual.
- Den skal udelukkende bruges til hjemmeformål.
- Garantien vil blive ugyldig, hvis produktet videresælges eller er blevet beskadiget som følge af ukvalificeret reparation.
- Specifikationer kan ændres uden varsel.
- Producenten frasiger sig alt ansvar for indirekte eller følgeskader.
- Garantien er i tillæg til, og formindsker ikke dine lovbestemte eller juridiske rettigheder.

E-mail: Techsupport@RFEinternational.com.

Garant: RFE Europa Ltd
8 Clarendon Drive
Wymbush, Milton Keynes
MK8 8ED, UK

Käyttäjän ohjeet



Vinoussäätö

Poista nappipultti M10 (19) ja jalkojen poikkitanko (5). Liikuta säätöjalkaa (2) ylös tai alas, kunnes penkki on halutulla korkeudella. Asenna jalkojen poikkitanko (5) ja nappipultti M10 (19) takaisin varmistaen, että pultti menee sekä (2):n että (3):n läpi.

Huom:

Yläpehmusteiden korkeutta voi myös säätää poistamalla yhden pehmusteiden ja siirtämällä putken toiseen asemaan.

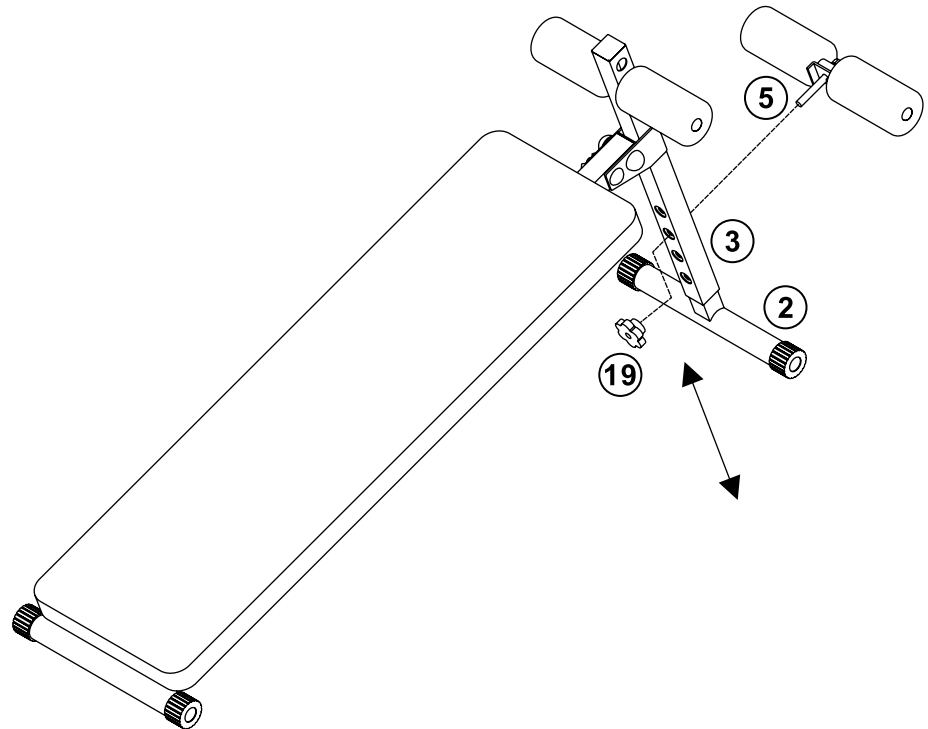

Säilytystä varten taittaminen

Poista siipimutteri (12) ja pultti (10). Käännä etujalkaa taaksepäin, kunnes se koskettaa pääputkea. Asenna siipimutteri ja pultti takaisin varastointia varten.

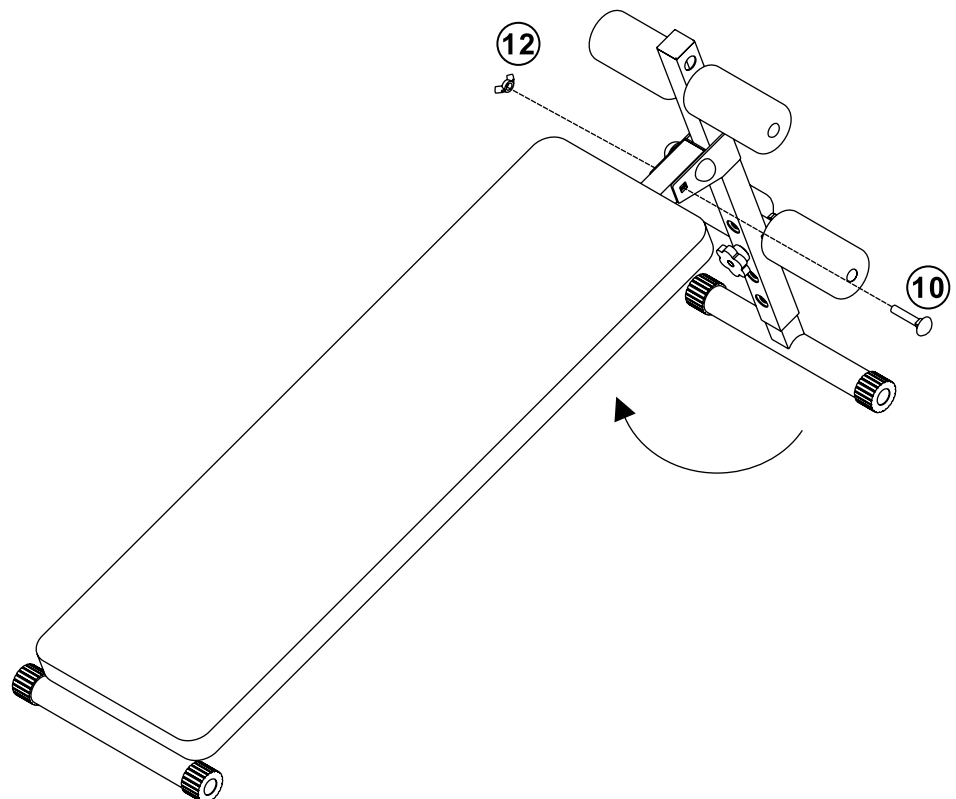

Osien räjäytyskaavio

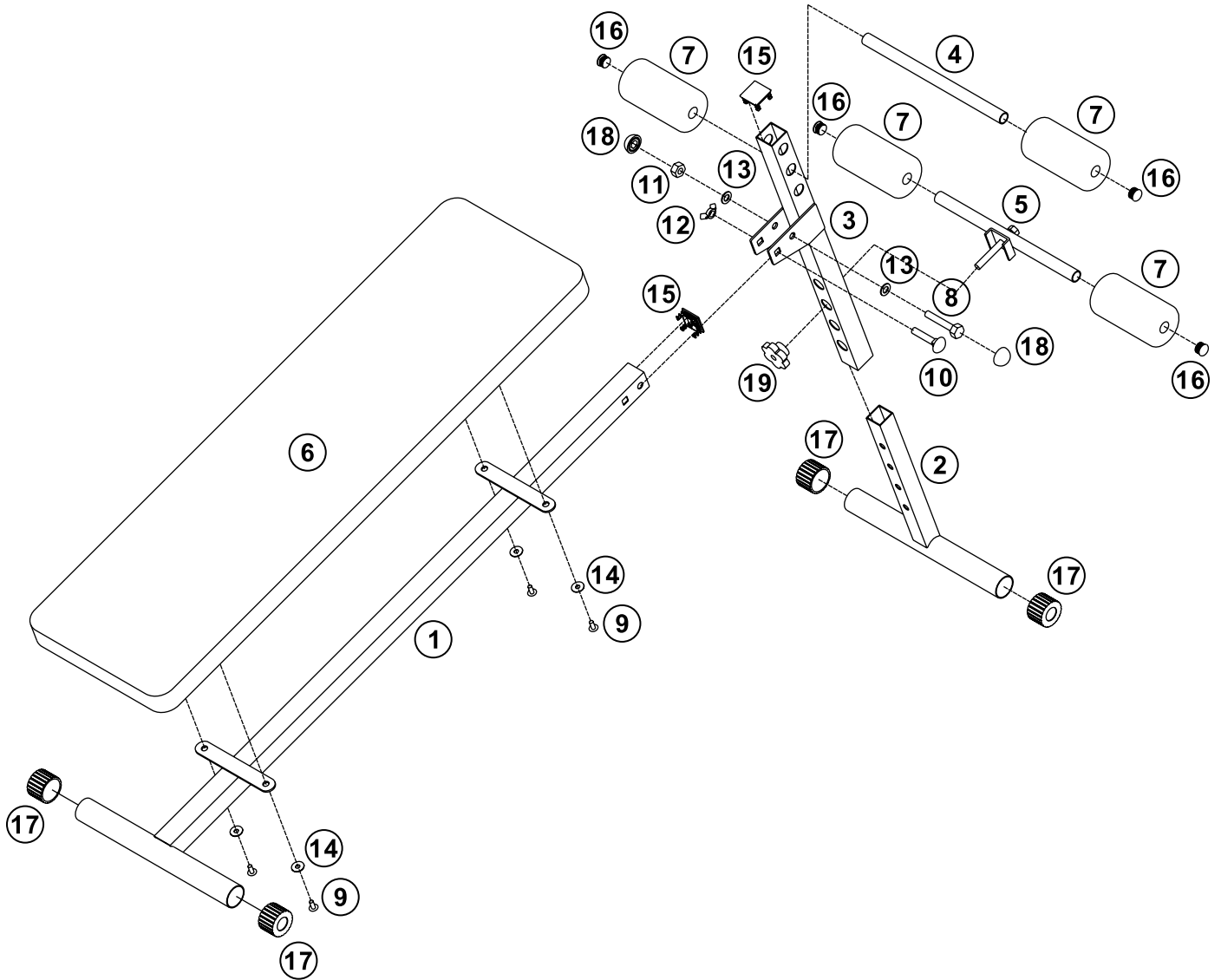

Räjätyskaavion osaluettelo



Osa	Kuvaus	Määrä
1	Päärunko	1
2	Säätöjalka	1
3	Etujalka	1
4	Jalkojen pehmustetanko	1
5	Jalkojen poikkitanko	1
6	Pehmustus	1
7	Pehmusterulla	4
8	M10 x 55 mm pultti	1
9	M6 x 15 mm ruuvi	4
10	M10 x 55 mm lukkopultti	1
11	M10 nailonlukkomutteri	1
12	M10 siipimutteri	1
13	M10 tiivisterengas	2
14	M6 tiivisterengas	4
15	35 mm nelikulmainen sisätulppa	2
16	19 mm pyöreä sisätulppa	4
17	38 mm pyöreä ulkoinen päätytulppa	4
18	Pulttitulppa	2
19	Nuppipultti M10	1



Tuotetakuu

Tämän tuotteen takuu kattaa valmistusvirheet ja kestää



vuoden

Tämän tuotteen takuaika on 12 kuukautta alkuperäisestä ostopäivästä alkaen. Kaikki takuaikana virheellisistä materiaaleista tai valmistusvirheestä johtuvat viat vaihtaa, hyvittää tai, mikäli mahdollista, korjaa veloituksetta se jälleenmyyjä, jolta tämä tuote on ostettu.

Takuuta koskevat seuraavat ehdot:

- Takuu ei kata tapaturmia, väärinkäyttöä, kotelon osia, nuppeja eikä kulutustarvikkeita.
- Tuote tulee asentaa asianmukaisesti ja sitä tulee käyttää tässä käsikirjassa olevien ohjeiden mukaisesti.
- Se on tarkoitettu vain kotikäyttöön.
- Takuu mitätöityy, mikäli tuote jälleenmyydään tai se on vahingoittunut epäammattimaisen korjaustyön seurauksena.
- Määritykset voivat muuttua ilman erillistä ilmoitusta.
- Valmistaja ei ota vastuuta mistään satunnaisista tai välillisistä vahingoista.
- Takuu ei vähennä ostajan lakisääteisiä tai laillisia oikeuksia vaan tulee niiden lisäksi.

Sähköposti: Techsupport@RFEinternational.com.

Takuun myöntäjä: RFE Europa Ltd
8 Clarendon Drive
Wymbush, Milton Keynes
MK8 8ED, Yhdistynyt kuningaskunta

Informations à l'attention de l'utilisateur



Réglage de la déclinaison

Remove Knob bolt M10 (19) and Leg cross bar (5). Slide adjustment leg (2) up or down until bench is at desired height. Refit Leg crossbar (5) and Knob bolt M10 (19) ensuring bolt passes through both (2) & (3).

Note: Top foam roller height can also be adjusted by removing 1 foam roller and repositioning the tube.

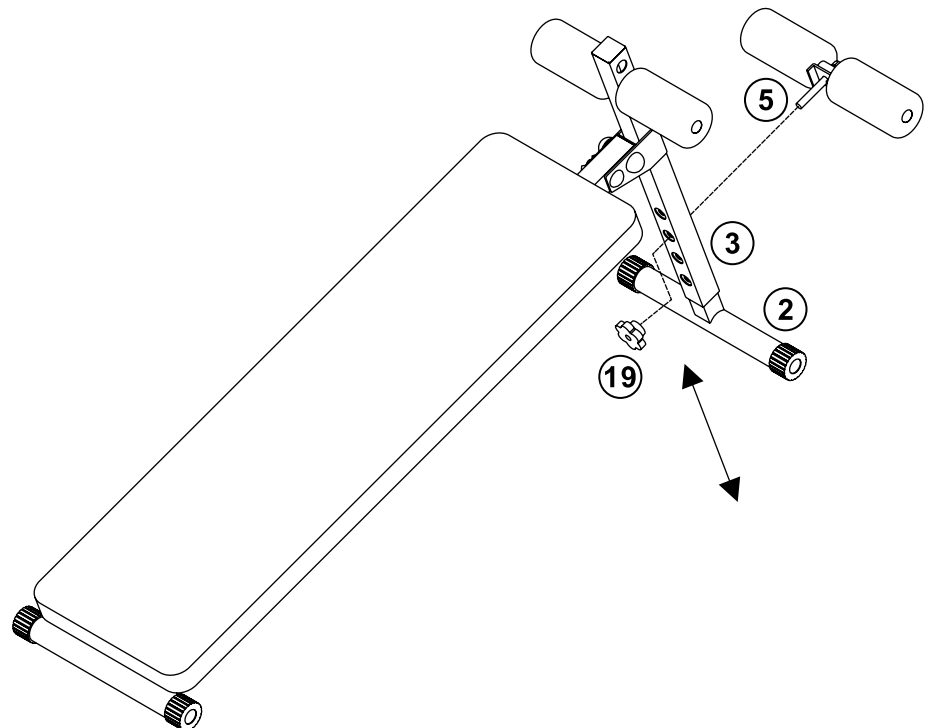

Pliage du banc

Retirer l'écrou papillon (12) et le boulon (10). Incliner le pied avant vers l'arrière jusqu'à ce que qu'il touche le support principal. Replacer le boulon et l'écrou papillon et ranger le banc.

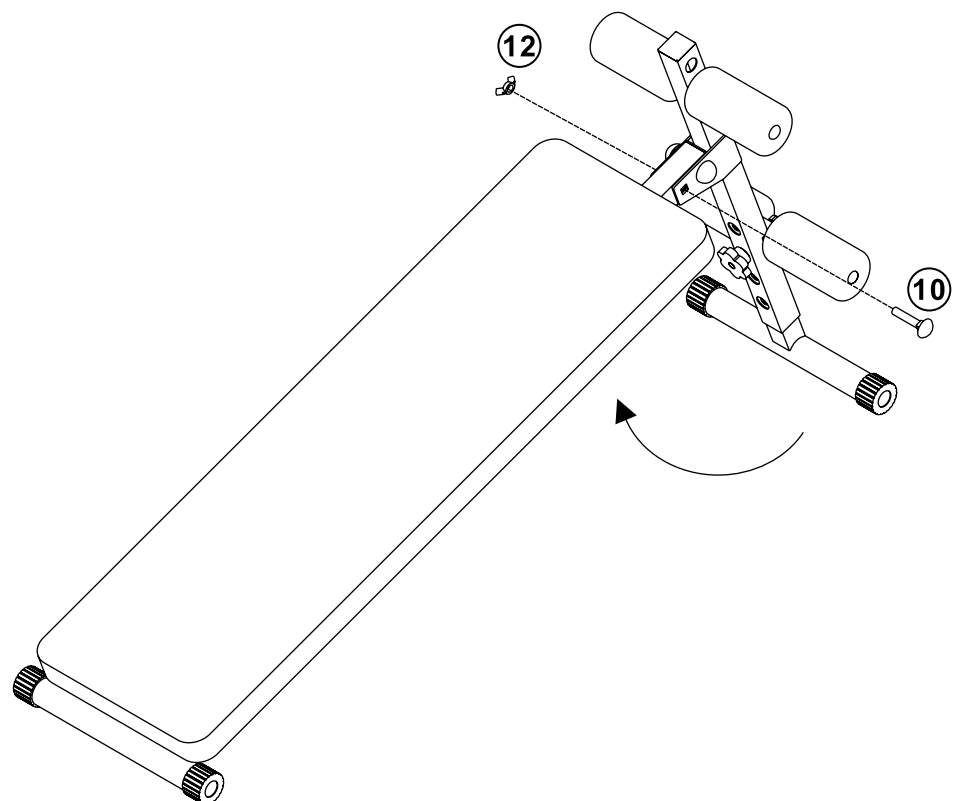

Vue éclatée des différentes pièces

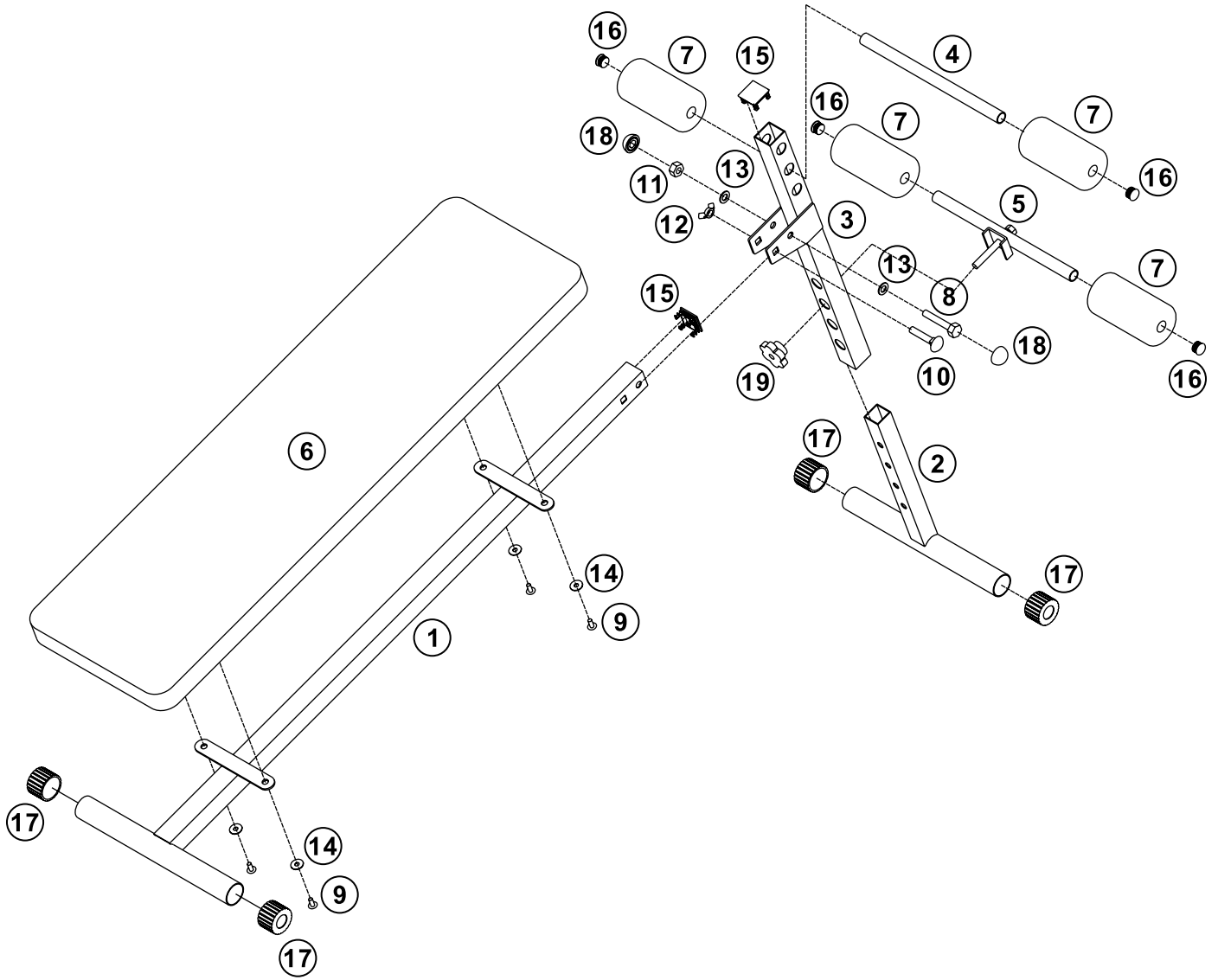

Liste des différentes pièces



Pièce	Description	Qté
1	Support principal	1
2	Pied réglable	1
3	Pied avant	1
4	Tube support des rouleaux en mousse	1
5	Barre transversale inférieure	1
6	Dossier	1
7	Rouleau en mousse	4
8	Boulon M10 x 55 mm	1
9	Vis M6 x 15 mm	4
10	Boulon à tête ronde M10 x 55 mm	1
11	Écrou-frein en nylon M10	1
12	Écrou papillon M10	1
13	Rondelle M10	2
14	Rondelle M6	4
15	Embout intérieur carré 35 mm	2
16	Embout intérieur rond 19 mm	4
17	Embout extérieur rond 38 mm	4
18	Cache boulon	2
19	Vis de blocage M10	1



Garantie du produit

Ce produit est garanti contre les défauts de fabrication pour une période de



Ce produit est garanti pour une durée de douze mois à compter de sa date d'achat. Tout défaut résultant d'un vice de matériau ou de fabrication entraînera le remplacement, le remboursement ou, si cela est possible, la réparation gratuite au cours de cette période, auprès du vendeur chez qui vous avez acheté le produit.

La garantie est soumise aux dispositions suivantes :

- La garantie ne couvre pas les dommages accidentels, la mauvaise utilisation, les pièces du meuble, les écrous ou les pièces consommables.
- Le produit doit être correctement assemblé et utilisé conformément aux instructions contenues dans ce manuel.
- Il doit être utilisé à des fins domestiques uniquement.
- La garantie sera rendue invalide si le produit est revendu ou a été endommagé lors d'une réparation effectuée par un non spécialiste.
- Les caractéristiques sont sujettes à modification, et ce sans préavis.
- Le fabricant rejette toute responsabilité en cas de dommages accessoires ou indirects.
- La garantie s'ajoute à vos droits légaux ou statutaires, sans les diminuer.

E-mail: Techsupport@RFEinternational.com.

Garant : RFE Europa Ltd,
8 Clarendon Drive
Wymbush, Milton Keynes
MK8 8ED, Royaume-Uni

Änderung der Schräge

Entfernen Sie den Sperrbolzen M10 (19) und die Stand-Querstange (5). Schieben Sie die Verstellstange (2) nach oben oder unten, bis sich die Bank auf der gewünschten Höhe befindet. Bringen Sie die Stand-Querstange (5) und den Sperrbolzen M10 (19) wieder an und stellen Sie sicher, dass die Schraube durch beide führt (2) & (3).

Anmerkung: Die Höhe der oberen Schaumstoffrolle kann auch eingestellt werden, indem Sie eine Schaumstoffrolle entfernen und das Rohr neu positionieren.

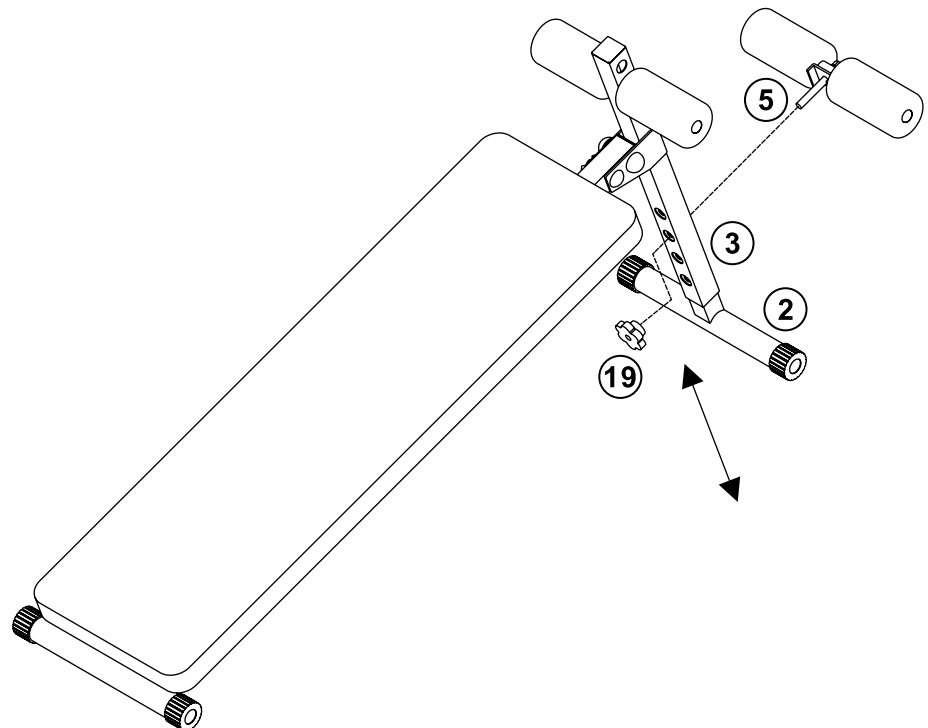

Zusammenklappen zur Lagerung

Entfernen Sie die Flügelmutter (12) und den Bolzen (10). Drehen Sie das vordere Standbein nach hinten, bis es das Hauptrohr berührt. Bringen Sie zur Lagerung Flügelmutter und Bolzen wieder an.

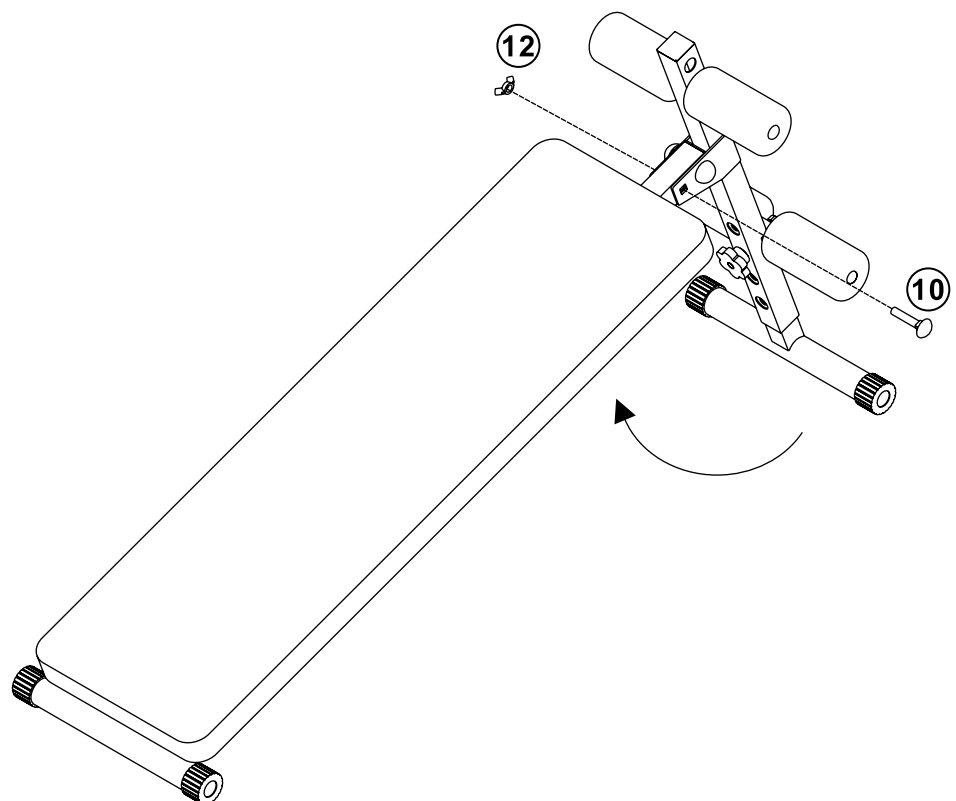

Explosionszeichnung

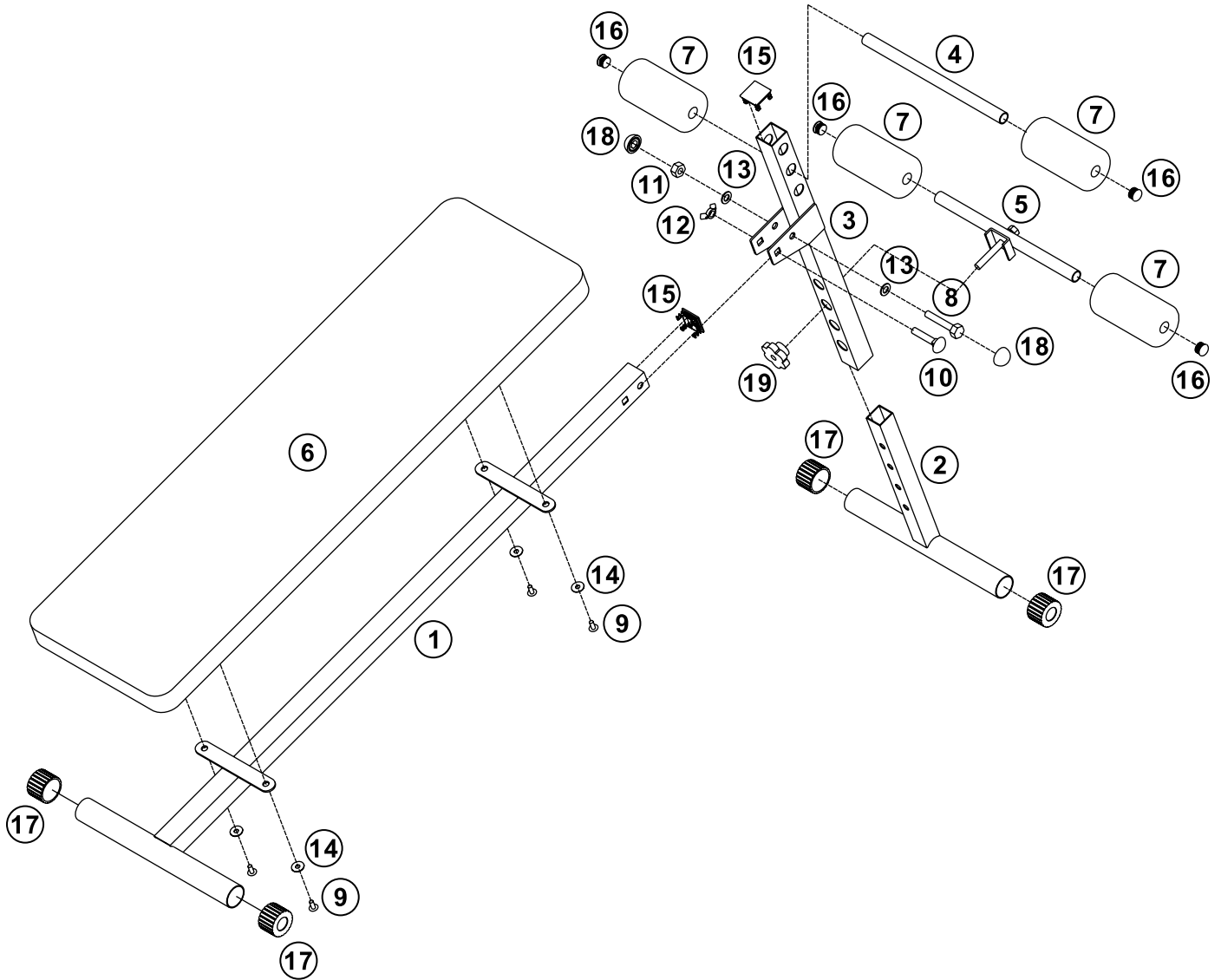

Teileübersicht



Teil	Beschreibung	Menge
1	Hauptrahmen	1
2	Verstellstange	1
3	Vorderes Standrohr	1
4	Schaumstoff-Montagestange	1
5	Stand-Querstange	1
6	Polster	1
7	Schaumstoffrolle	4
8	M10 x 55 mm Schraubbolzen	1
9	M6 x 15 mm Schraube	4
10	M10 x 55 mm Schlossschraube	1
11	M10 Nylon-Feststellmutter	1
12	M10 Flügelmutter	1
13	M10 Scheibe	2
14	M6 Scheibe	4
15	35 mm eckige innere Kappe	2
16	19 mm runde innere Kappe	4
17	38 mm runde externe Verschlusskappe	4
18	Schraubenkappe	2
19	Sperrbolzen M10	1



Produktgarantie

Dieses Produkt ist gegen Herstellungsfehler für den folgenden Zeitraum abgesichert



Jahr

Das Produkt ist ab dem Datum des ursprünglichen Kaufs für einen Zeitraum von zwölf Monaten abgesichert. Alle Schäden, die aufgrund von fehlerhaften Materialien oder fehlerhafter Verarbeitung entstehen, werden wenn möglich während dieser Zeitspanne entweder ersetzt, erstattet oder kostenfrei repariert. Dies wird von dem Händler, wo Sie das Gerät gekauft haben, durchgeführt.

Die Garantie unterliegt den folgenden Bestimmungen:

- Die Garantie umfasst keine versehentlichen Schäden, keinen Missbrauch, keine Teile des Gehäuses, Knöpfe oder verzehrbare Teile.
- Das Produkt muss korrekt in Übereinstimmung mit den in dieser Anleitung enthaltenen Anweisungen installiert und bedient werden.
- Dieses Gerät ist ausschließlich für die Nutzung zu nichtgewerblichen Zwecken bestimmt.
- Die Garantie wird ungültig, wenn das Produkt weiterverkauft oder durch nicht fachgerechte Reparaturen beschädigt wird.
- Spezifikationen können fristlos geändert werden.
- Der Hersteller lehnt jegliche Haftung für Schäden, die im direkten oder indirekten Zusammenhang hiermit entstehen, ab.
- Die Garantie gilt zusätzlich zu Ihren satzungsmäßigen und gesetzlichen Rechten und hat keinerlei Einfluss auf diese.

E-Mail: Techsupport@RFEinternational.com.

Garant: RFE Europa Ltd
8 Clarendon Drive
Wymbush, Milton Keynes
MK8 8ED, GB

Αναπτυγμένο διάγραμμα εξαρτημάτων

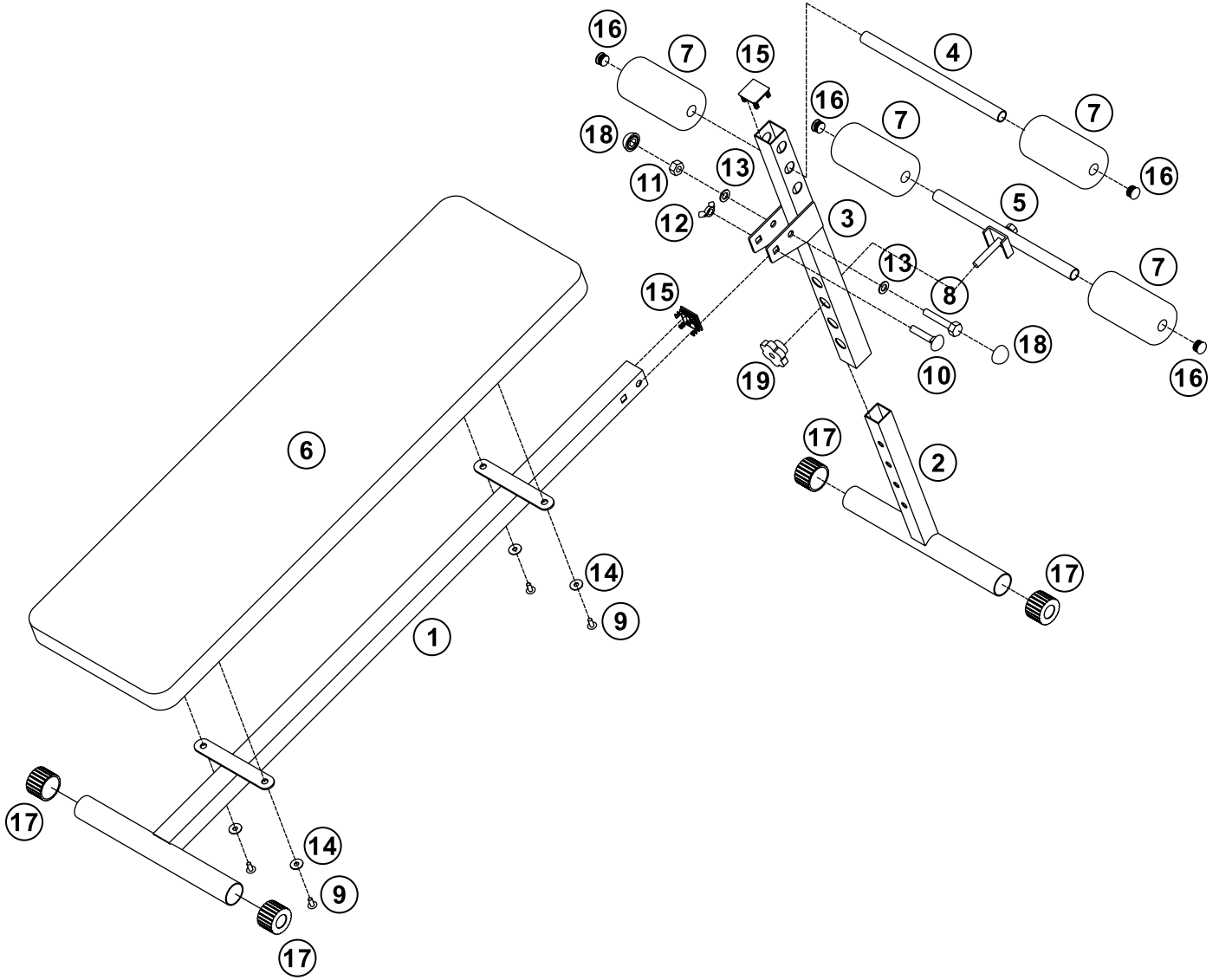

Λίστα αναπτυγμένου διαγράμματος εξαρτημάτων



Εξάρ- τημα	Περιγραφή	Ποσό- τητα
1	Κύριος σκελετός	1
2	Πόδι ρύθμισης	1
3	Μπροστινό πόδι	1
4	Αφρώδης σωλήνας στήριξης	1
5	Σταυρωτή μπάρα ποδιών	1
6	Επένδυση	1
7	Ρολό αφρού	4
8	Πείρος M10 x 55mm	1
9	Βίδα M6 x 15mm	4
10	Πείρος μεταφοράς M10 x 55mm	1
11	Νάιλον παξιμάδι ασφάλισης M10	1
12	Πεταλούδα M10	1
13	Ροδέλα M10	2
14	Ροδέλα M6	4
15	Τετράγωνο εσωτερικό καπάκι 35mm	2
16	Στρογγυλό εσωτερικό καπάκι 19mm	4
17	Στρογγυλό εξωτερικό καπάκι 38mm	4
18	Καπάκι πείρου	2
19	Πείρος μοχλού M10	1



Εγγύηση προϊόντος

Αυτό το προϊόν έχει εγγύηση η οποία καλύπτει κατασκευαστικά ελαττώματα για περίοδο



έτος

Αυτό το προϊόν έχει εγγύηση δώδεκα μηνών από την ημερομηνία της αρχικής αγοράς. Σε περίπτωση ελαττώματος που προκύπτει εξαιτίας ελαττωματικών υλικών ή κακοτεχνίας, παρέχεται αντικατάσταση, επιστροφή χρημάτων ή επισκευή χωρίς χρέωση, εάν αυτό είναι δυνατό, κατά τη διάρκεια αυτής της περιόδου από τον αντιπρόσωπο από τον οποίο αγοράσατε το προϊόν.

Η εγγύηση υπόκειται στις ακόλουθες διατάξεις:

- Η εγγύηση δεν καλύπτει ζημιά από ατύχημα, κακή χρήση, εξαρτήματα προθήκης, μοχλούς ή αναλώσιμα είδη.
- Το προϊόν πρέπει να είναι εγκατεστημένο σωστά και ο χειρισμός του να γίνεται σύμφωνα με τις οδηγίες που περιλαμβάνονται στο παρόν εγχειρίδιο.
- Προορίζεται αποκλειστικά για οικιακή χρήση.
- Η εγγύηση δεν ισχύει στην περίπτωση μεταπώλησης του προϊόντος ή σε περίπτωση ζημιάς από επισκευή από μη-ειδικό.
- Οι προδιαγραφές ενδέχεται να αλλάξουν χωρίς ειδοποίηση.
- Ο κατασκευαστής αποποιείται οποιασδήποτε ευθύνης σχετικά με δευτερεύουσες ή επακόλουθες ζημιές.
- Η εγγύηση λειτουργεί συμπληρωματικά, χωρίς να περιορίζει τα νόμιμα δικαιώματά σας.

Email: Techsupport@RFEinternational.com.

Εγγυητής: RFE Europa Ltd
8 Clarendon Drive
Wymbush, Milton Keynes
MK8 8ED, Ηνωμένο Βασίλειο

Informazioni per l'utente



Regolazione dell'inclinazione

Rimuovere il pomello di fissaggio M10 (19) e la traversa per le gambe (5). Far scorrere la staffa di regolazione (2) verso l'alto o verso il basso fino a quando la panca non si troverà all'altezza desiderata. Reinscrivere la traversa per le gambe (5) e il pomello di fissaggio M10 (19) verificando che il bullone passi attraverso (2) e (3).

Nota: L'altezza del rullo in spuma superiore può essere regolata anche rimuovendo 1 rullo di schiuma e riposizionando il tubo.

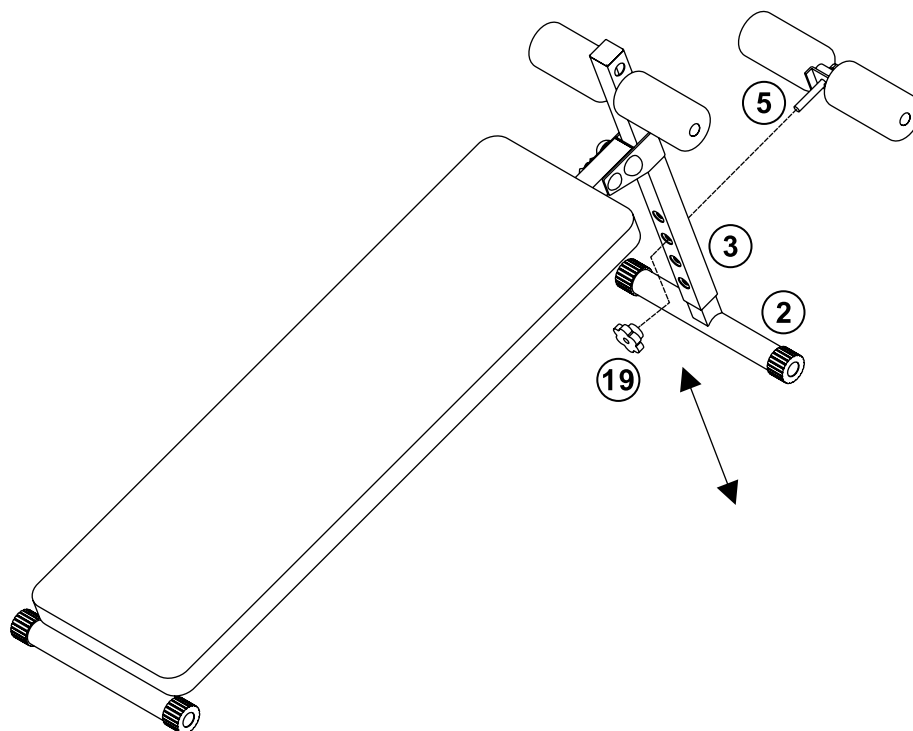

Come richiudere l'attrezzatura prima di riporla

Rimuovere il dado ad alette (12) e il bullone (10). Ruotare la staffa anteriore all'indietro fino a toccare il tubo principale. Reinscrivere il dado ad alette e il bullone prima di riporre l'attrezzatura dopo l'uso.

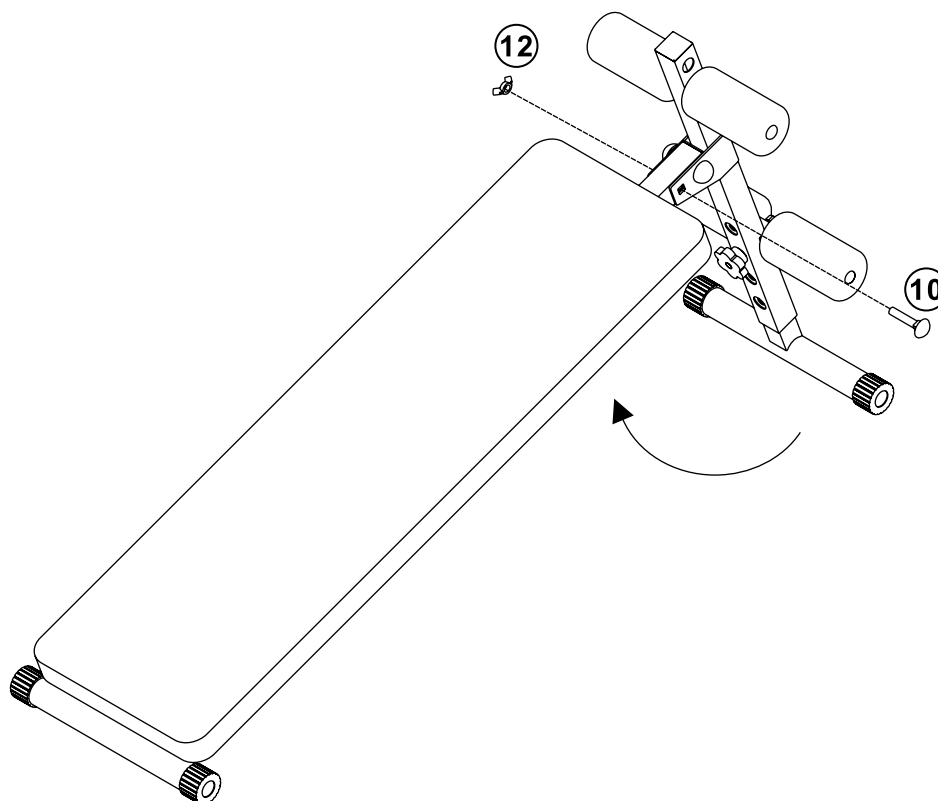

Disegno esploso delle parti di ricambio

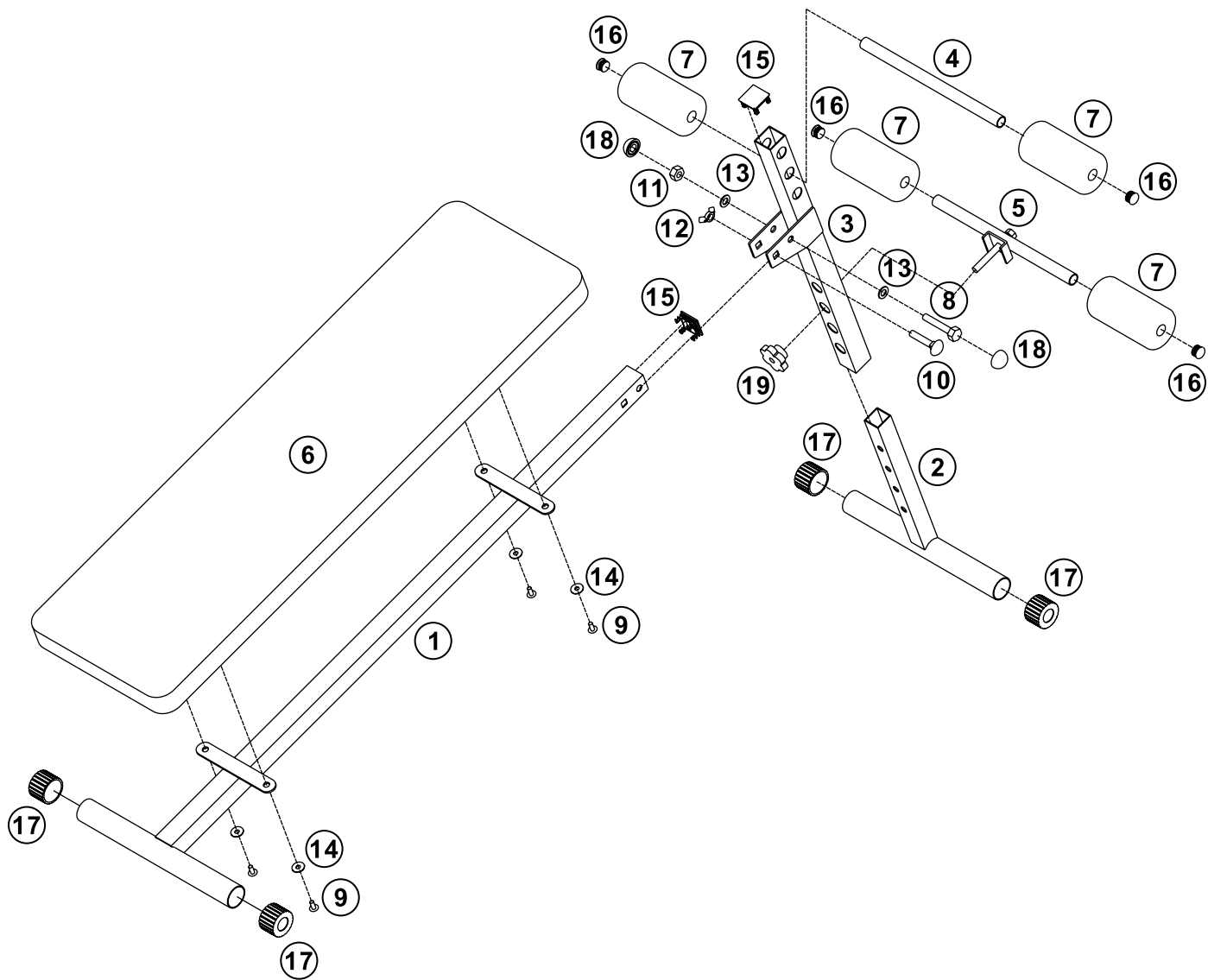

Disegno esploso e lista delle parti di ricambio



Parte	Descrizione	Quantità
1	Telaio principale	1
2	Staffa di regolazione	1
3	Staffa anteriore	1
4	Staffa di montaggio imbottitura	1
5	Traversa per le gambe	1
6	Imbottitura	1
7	Rullo in spuma	4
8	Bullone M10 x 55 mm	1
9	Vite M6 x 15 mm	4
10	Bullone carrello M10 x 55 mm	1
11	Dado di bloccaggio con inserto in nylon M10	1
12	Dado ad alette M10	1
13	Rondella M10	2
14	Rondella M6	4
15	Tappo interno quadrato 35 mm	2
16	Tappo interno circolare 19mm	4
17	Tappo terminale esterno 38 mm	4
18	Tappo del bullone	2
19	Pomello di fissaggio M10	1



Garanzia del prodotto

Questo prodotto è coperto da una garanzia sui difetti di fabbricazione per un periodo di



anno

Questo prodotto è coperto da una garanzia valida per dodici mesi dalla data di acquisto iniziale. A fronte di qualsiasi problema derivante da materiali difettosi o difetti di lavorazione, durante questo periodo è prevista la sostituzione dei pezzi interessati, il rimborso o la riparazione gratuita, se possibile, da parte del rivenditore presso il quale è stata acquistata l'unità.

La garanzia è soggetta alle seguenti condizioni:

- La garanzia non copre danni accidentali, danni derivanti da uso improprio, parti dell'armadietto, manopole o materiali di consumo.
- Il prodotto deve essere installato e messo in funzione correttamente seguendo le istruzioni contenute in questo manuale.
- Il prodotto è destinato unicamente all'utilizzo domestico.
- La garanzia sarà invalidata se il prodotto viene rivenduto o viene danneggiato a seguito di riparazioni non eseguite in modo professionale.
- Le specifiche sono soggette a modifiche senza preavviso.
- Il produttore declina qualsiasi responsabilità per danni accidentali o conseguenti.
- La garanzia è da considerarsi un'integrazione e non limita i diritti legali o giuridici dell'utente.

E-mail: Techsupport@RFEinternational.com.

Garante: RFE Europa Ltd
8 Clarendon Drive
Wymbush, Milton Keynes
MK8 8ED, Regno Unito

Aanpassing van de helling

Verwijder knopbout M10 (19) en de voetstang (5). Schuif het verstelbare frame (2) omhoog of omlaag tot de bench op de gewenste hoogte staat. Maak de voetstang (5) en de knopbout M10 (19) weer vast en verzeker u ervan dat de bout zowel door onderdeel (2) als deel (3) gaat.

Let op: De hoogte van de bovenste foamgreep kan worden aangepast door 1 foamrol te verwijderen en de stang een andere positie te geven.

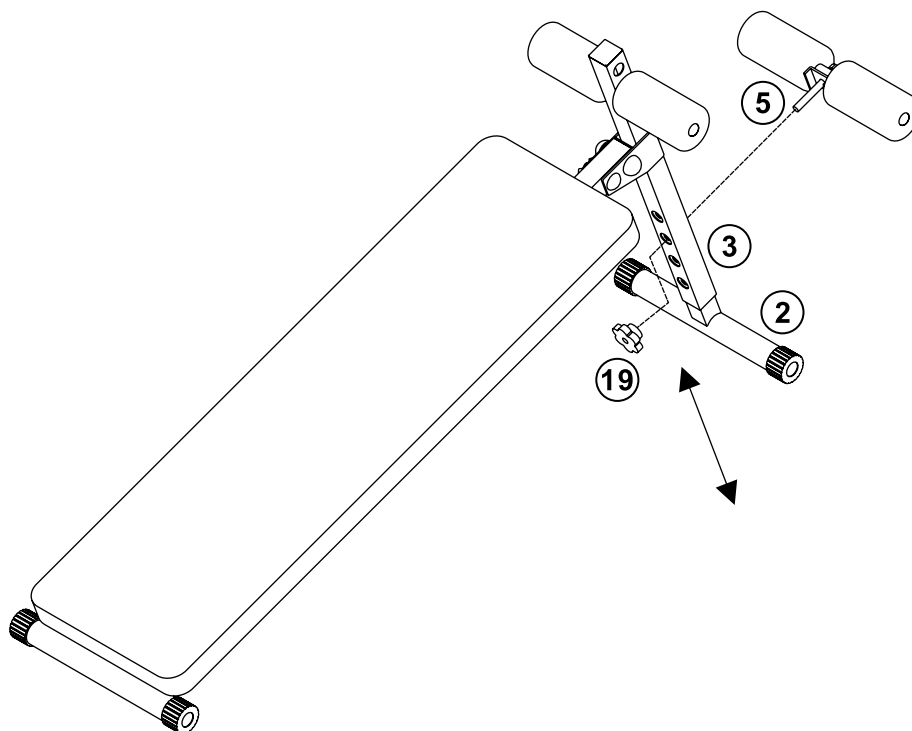

Opvouwen voor opslag

Verwijder vleugelmoer (12) en bout (10). Draai het draagframe naar achteren totdat deze het hoofdframe raakt. Plaats bout en vleugelmoer terug voor opslag.

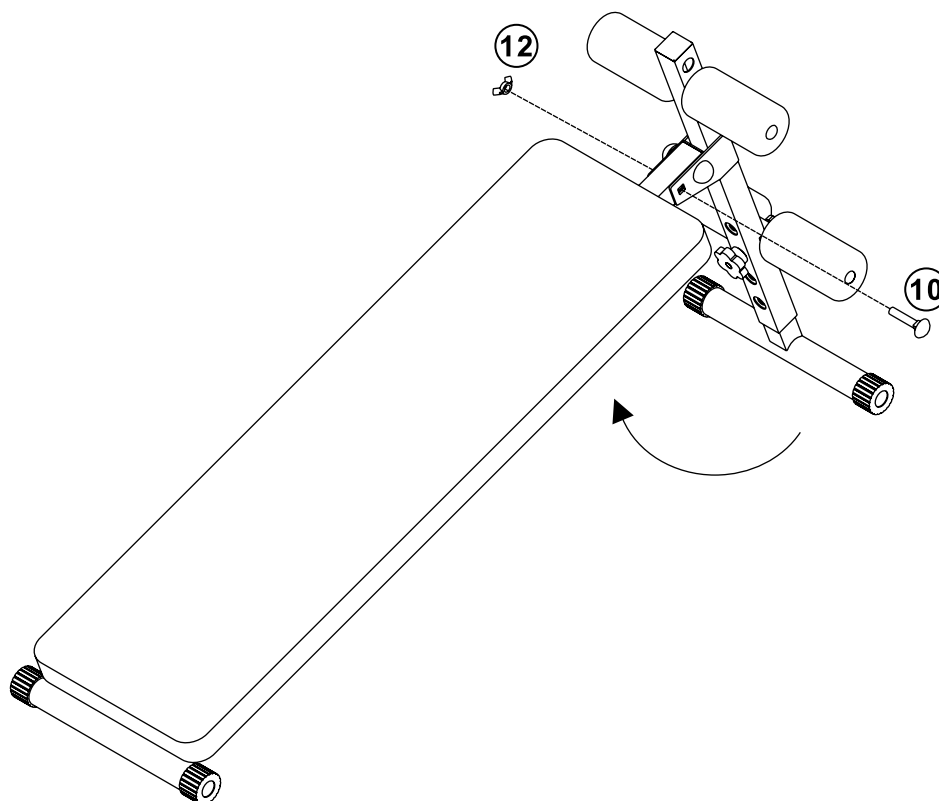

Overzichtstekening

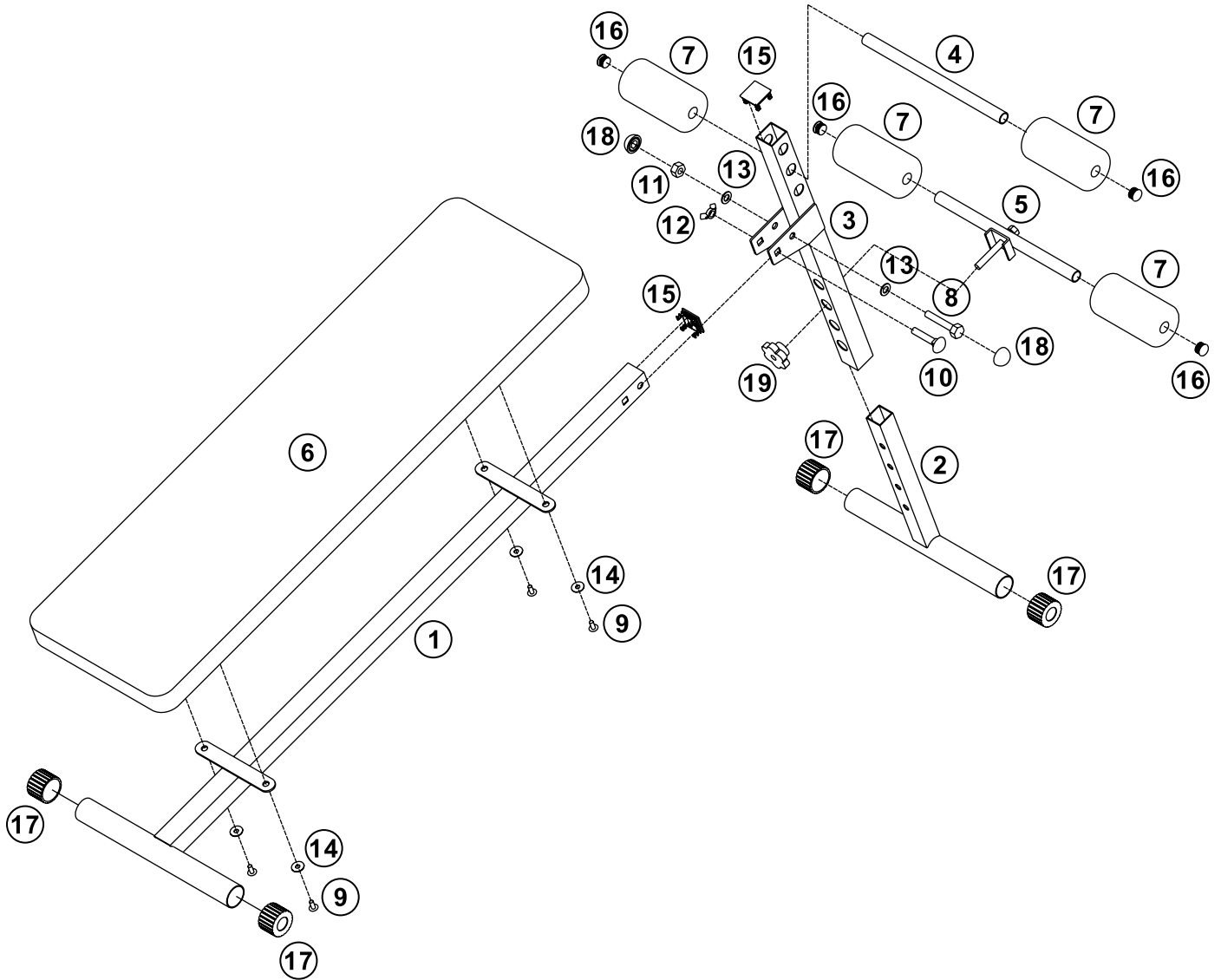

Onderdelenlijst



Onder-deel	Omschrijving	Aantal
1	Hoofdframe	1
2	Verstelbaar frame	1
3	Draagframe	1
4	Voet foamgreep	1
5	Voetstang	1
6	Rugsteun	1
7	Foamrol	4
8	M10 x 55mm bout	1
9	M6 x 15mm schroef	4
10	M10 x 55mm slotbout	1
11	M10 nylon borgmoer	1
12	M10 vleugelmoer	1
13	M10 sluitring	2
14	M6 sluitring	4
15	35mm vierkant afdekkapje	2
16	19mm rond afdekkapje	4
17	38mm ronde antislipvoet	4
18	Boutkap	2
19	Knopbout M10	1



Productgarantie

Dit product heeft een garantie op fabrieksfouten gedurende



jaar

Dit product heeft een garantie van 12 maanden vanaf de datum van de eerste aankoop. Elk defect dat, binnen deze periode, veroorzaakt wordt door materiaalfouten of productiefouten zal waar mogelijk kosteloos vervangen, vergoed of gerepareerd worden door de dealer waar u het product hebt gekocht.

De garantie is onderhevig aan de volgende bepalingen:

- De garantie geldt niet voor schade door ongeval, verkeerd gebruik, kastonderdelen, knoppen of verbruiksartikelen.
- Het product moet correct worden gemonteerd en gebruikt in overeenstemming met de instructies in deze handleiding.
- Het moet uitsluitend worden ingezet voor thuisgebruik.
- De garantie vervalt als het product wordt doorverkocht of is beschadigd door ondeskundige reparatie.
- De specificaties kunnen zonder voorafgaande kennisgeving worden gewijzigd.
- De fabrikant wijst elke aansprakelijkheid voor de incidentele of gevolgschade af.
- De garantie is een aanvulling op, en neemt niet de plaats in van uw wettelijke rechten.

Email: Techsupport@RFEinternational.com.

Garantieverlener: RFE Europa Ltd
8 Clarendon Drive
Wymbush, Milton Keynes
MK8 8ED, Verenigd Koninkrijk

Brukerinformasjon



Justering nedover

Ta av fingerbolt M10 (19) og ben til tverrstolpen (5). Skyv ben-justering (2) opp eller ned til benken er i ønsket høyde. Remonter tverrstolpen til bena (5) og fingerbolt M10 (19). Sikre at bolten går gjennom både (2) og (3).

Merk: Høyden til øverste skumvalse kan også justeres ved å fjerne én skumvalse og omposisjonere røret.

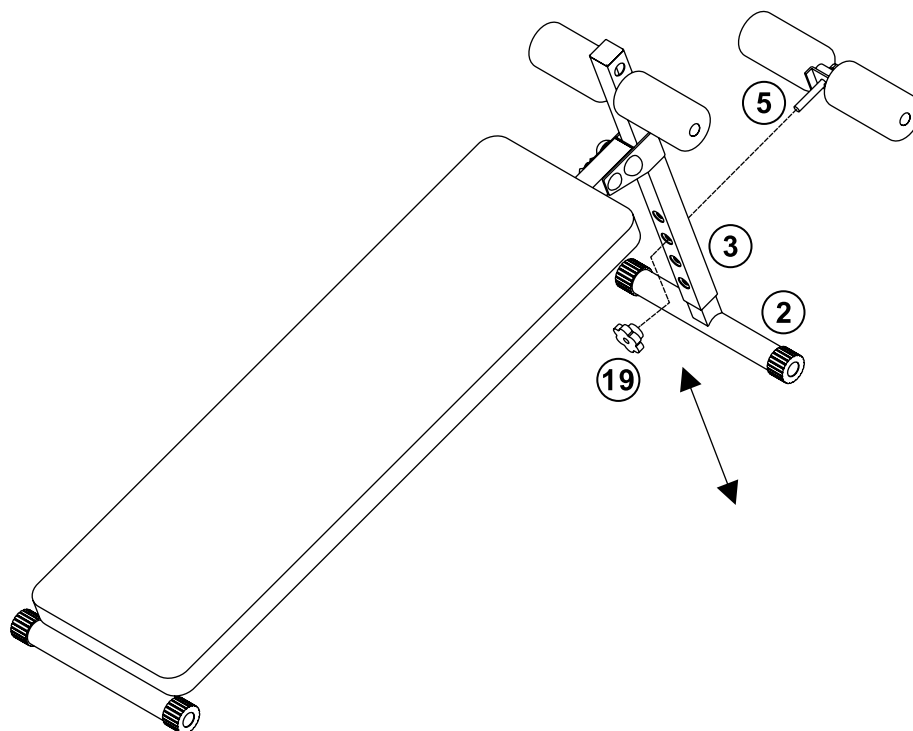

Legg sammen til lagring

Ta ut vingemutteren (12) og bolten (10). Roter fremre ben bakover til det berører hovedrøret. Remonter vingemutteren og bolten for lagring.

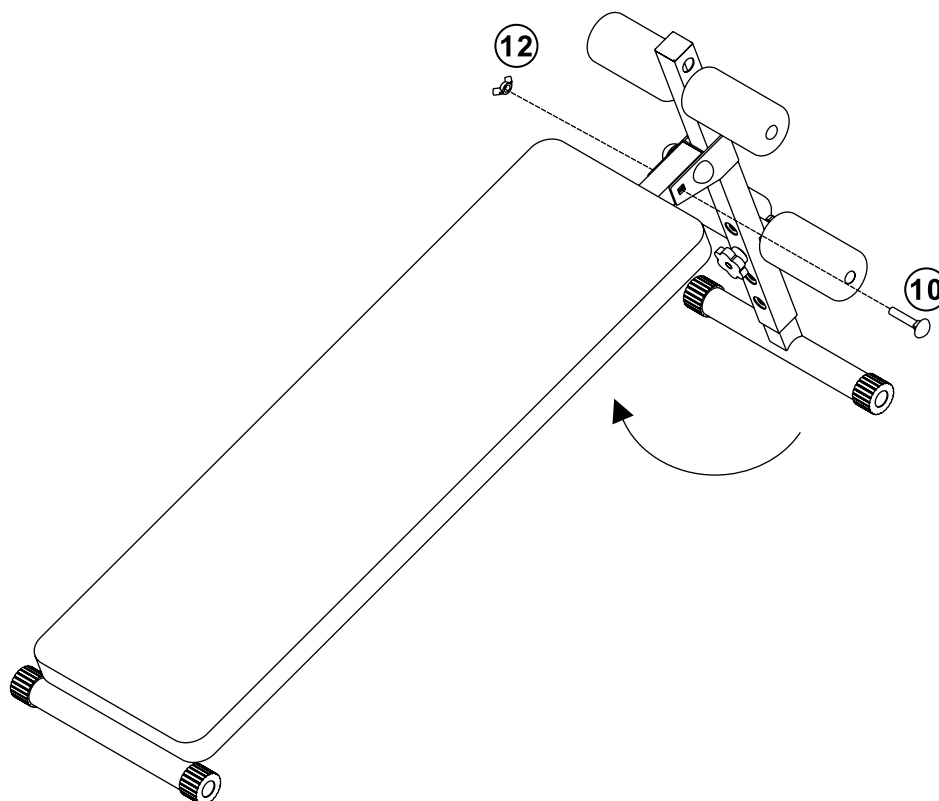

Splittegning deler

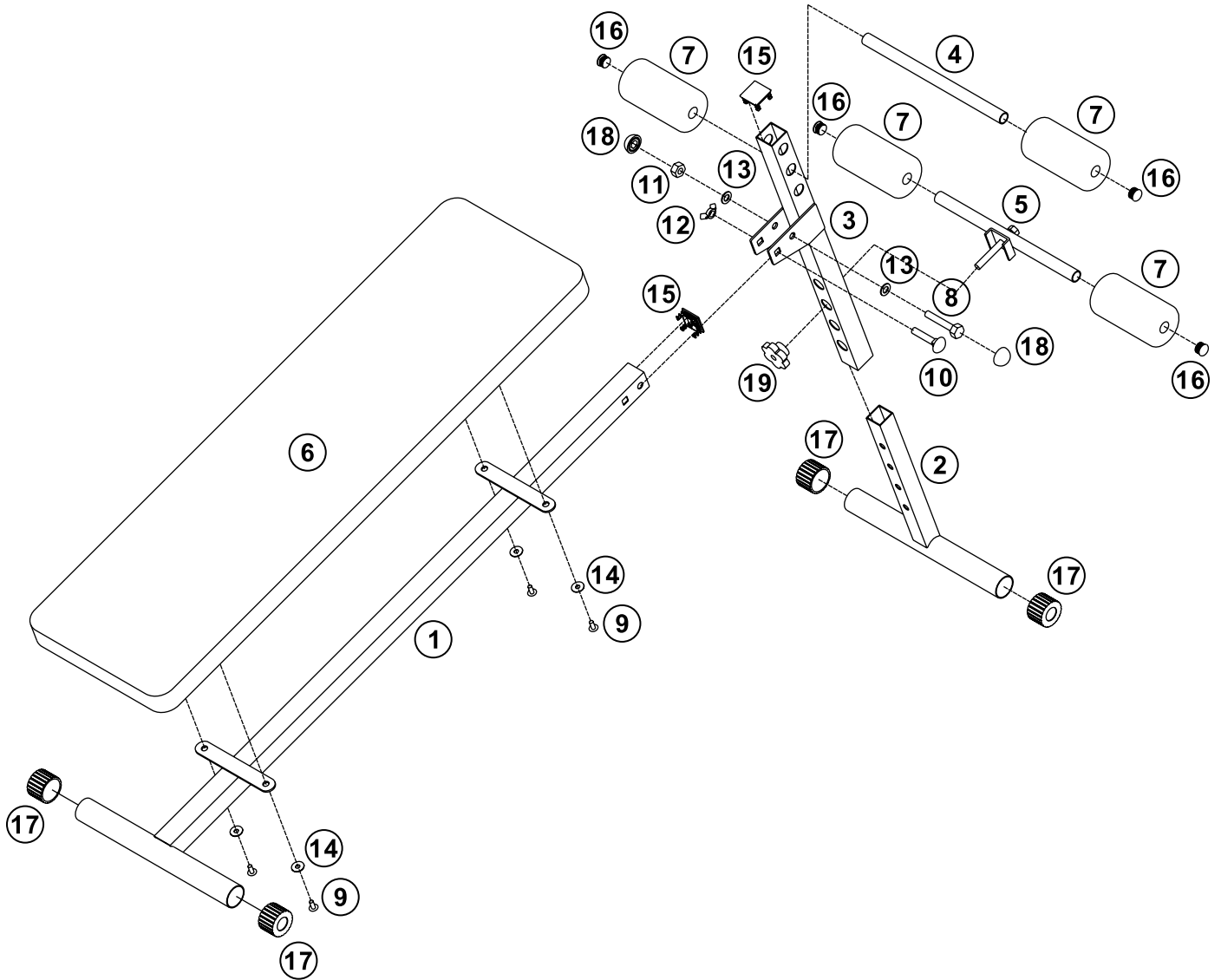

Splittegning deleliste



Del	Beskrivelse	Antall
1	Hovedramme	1
2	Justeringsben	1
3	Ben foran	1
4	Skum monteringsrør	1
5	Ben tverrstolpe	1
6	Sete	1
7	Skumvalse	4
8	M10 x 55 mm bolt	1
9	M6 x 15 mm skrue	4
10	M10 x 55 mm vognbolt	1
11	M10 nylon låsebolt	1
12	M10 vingemutter	1
13	M10 skive	2
14	M6 skive	4
15	35 mm firkantet indre hette	2
16	19 mm rund indre hette	4
17	38 mm rund utvendig endestykke	4
18	Bolthette	2
19	Fingerbolt M10	1



Produktgaranti

Dette produktet er garantert mot produksjonsfeil for en periode på



Ett år

Dette produktet er garantert i tolv måneder fra den opprinnelige kjøpsdatoen. Enhver defekt som oppstår grunnet feil i materialer eller utførelse vil enten bli erstattet, refundert eller reparert gratis, der det er mulig i denne perioden, av forhandleren der du kjøpte apparatet.

Denne garantien er underlagt følgende vilkår:

- Denne garantien dekker ikke skader som skyldes uhell, misbruk, kabinettdeler, Knotter eller forbruksvarer.
- Produktet må installeres riktig og betjenes i samsvar med anvisningene i denne håndboken.
- Det må brukes kun til hjemmebruk.
- Garantien ugyldiggjøres hvis produktet selges videre eller har fått skader av ukyndig reparasjon.
- Spesifikasjoner kan endres uten forvarsel.
- Produsenten fraskriver seg ethvert ansvar for tilfeldige eller følgeskader.
- Garantien kommer i tillegg til, og reduserer ikke dine lovbestemte eller juridiske rettigheter.

E-post: Techsupport@RFEinternational.com.

Garantist: RFE Europa Ltd
8 Clarendon Drive
Wymbush, Milton Keynes
MK8 8ED, UK

Informação do utilizador



Rejeitar ajuste

Retirar a porca M10 (19) e barra transversal da perna (5). Deslize a perna de ajuste (2) para cima ou para baixo até o banco ficar à altura desejada. Volte a colocar a barra transversal da perna (5) e a porca M10 (19) certificando-se de que o parafuso passa por ambos (2) & (3).

Nota: A altura do rolo de espuma superior também pode ser ajustada removendo 1 rolo de espuma e reposicionando o tubo.

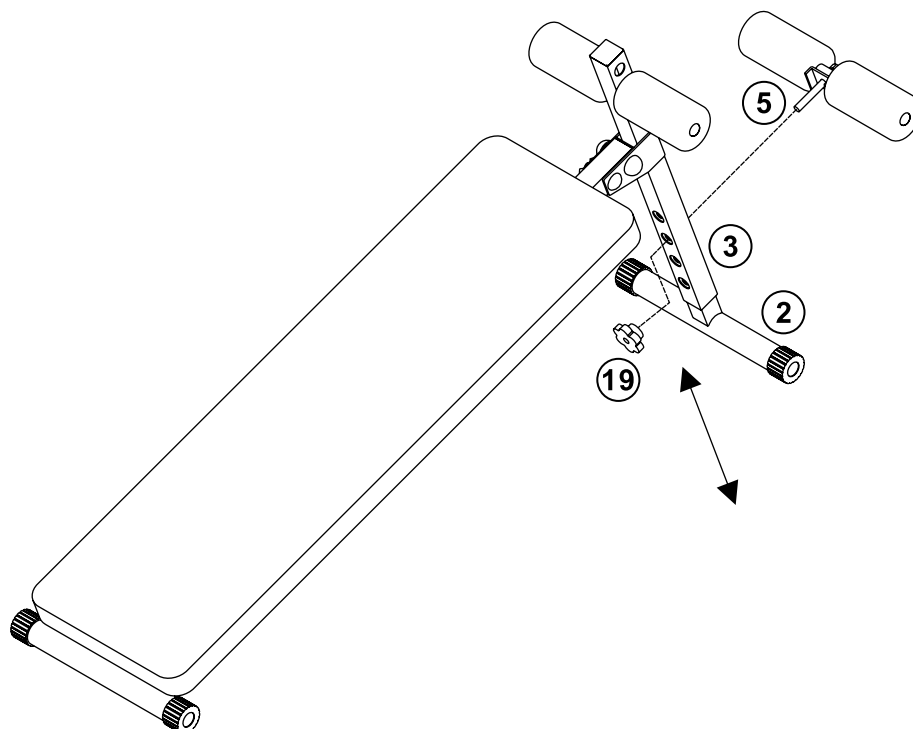

Dobrar para armazenar.

Retire a porca de orelhas (12) e o parafuso (10). Rode a perna frontal para trás até esta tocar no tubo principal. Volte a colocar a porca de orelhas e o parafuso para armazenamento.



Diagrama de peças em detalhado



Lista do diagrama de peças em detalhado

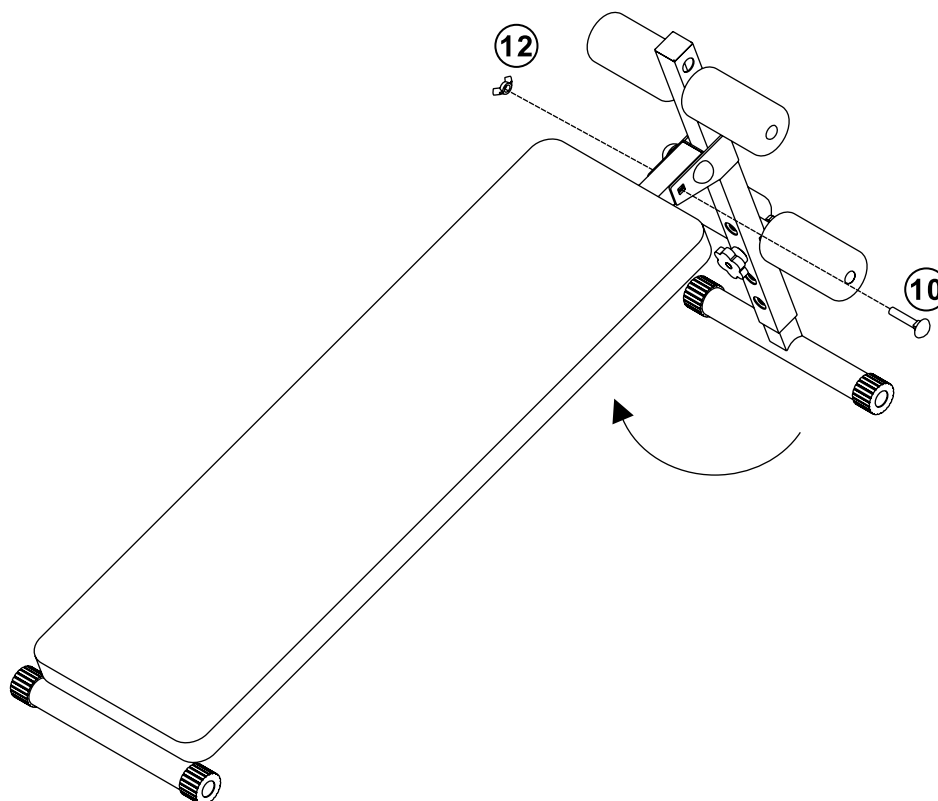
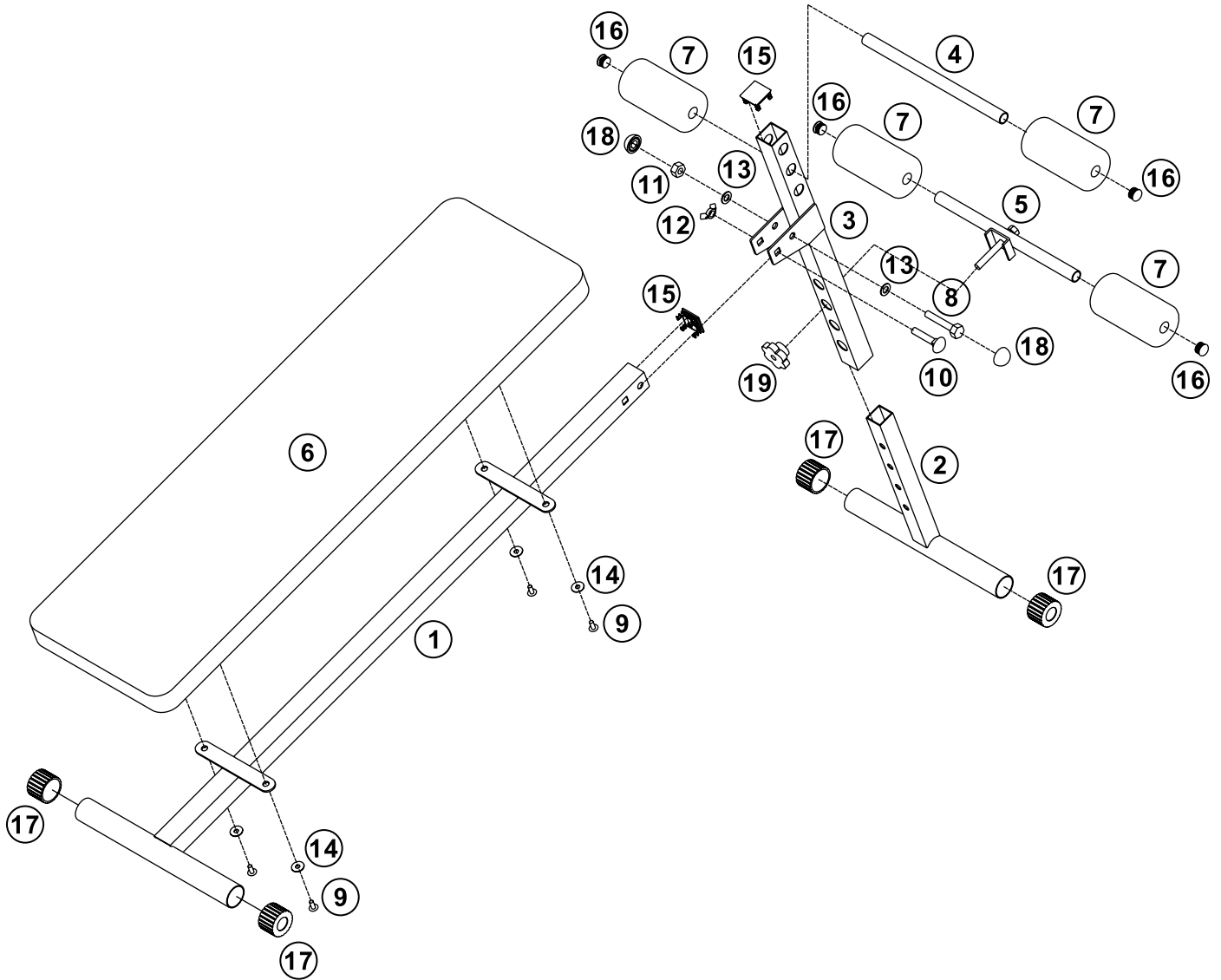

Peça	Descrição	Qtd
1	Estrutura principal	1
2	Perna de ajuste	1
3	Perna frontal	1
4	Barra de espuma da perna	1
5	Barra transversal da perna	1
6	Revestimento	1
7	Rolo de espuma	4
8	Parafuso M10 x 55mm	1
9	Parafuso M6 x 15mm	4
10	Parafuso M10 x 55mm	1
11	Porca de segurança em Nylon M10	1
12	Porca de orelhas M10	1
13	Anilha M10	2
14	Anilha M6	4
15	Tampa interior quadrada 35mm	2
16	Tampa interior redonda 19mm	4
17	Tampa exterior redonda 38mm	4
18	Tampa para parafuso	2
19	Porca de aperto manual M10	1



Garantia do produto

Este produto tem garantia contra defeitos de fabrico durante um período de



ano

Este produto tem a garantia de doze meses a partir da data original da compra. Qualquer defeito que surja devido a materiais defeituosos ou fabrico defeituoso será substituído, reembolsado ou reparado gratuitamente sempre que possível durante este período pelo vendedor a quem adquiriu a unidade.

A garantia está sujeita às seguintes disposições:

- A garantia não abrange danos acidentais, uso incorrecto, peças do gabinete, puxadores ou itens consumíveis.
- O produto deve ser correctamente instalado e operado de acordo com as instruções deste manual.
- Deve ser usado apenas para fins domésticos.
- A garantia será considerada inválida se o produto for novamente vendido ou tiver sido danificado numa reparação indevida.
- As especificações são sujeitas a alterações sem aviso prévio.
- O fabricante rejeita a responsabilidade por danos incidentais ou indirectos.
- A garantia complementa e não afecta os seus direitos legais.

Email: Techsupport@RFEinternational.com.

Garante: RFE Europa Ltd
8 Clarendon Drive
Wymbush, Milton Keynes
MK8 8ED, Reino Unido

Información para el usuario



Ajuste de la inclinación negativa

Extraiga la perilla M10 (19) y el apoyo inferior (5). Deslice la pata de regulación (2) hacia arriba o hacia abajo hasta la altura que desee. Vuelva a montar el apoyo inferior (5) y la perilla M10 (19), asegurándose de que el tornillo pase tanto por (2) como por (3).

Nota: También se puede ajustar la altura de los rodillos del apoyo superior desmontando 1 rodillo de espuma y colocando el apoyo en otro lugar de la barra.

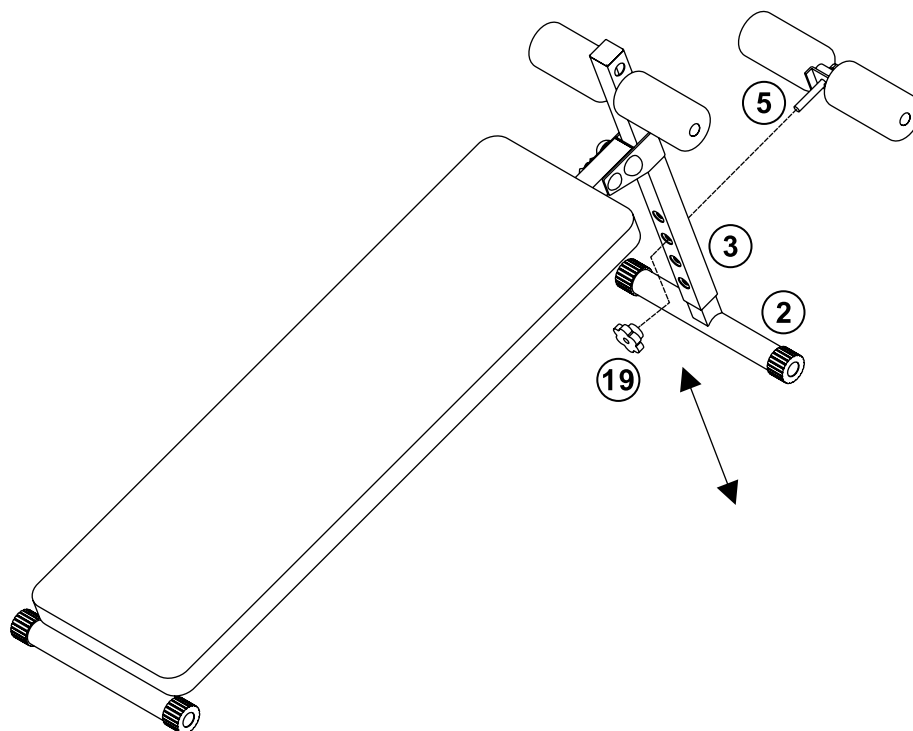

Plegado y almacenamiento

Extraiga la tuerca de aletas (12) y el tornillo (10). Pliegue la pata frontal hacia atrás hasta que toque la barra principal. Vuelva a montar la tuerca de aletas y el tornillo para asegurar el banco.



Diagrama de despiece



Leyenda del diagrama de despiece

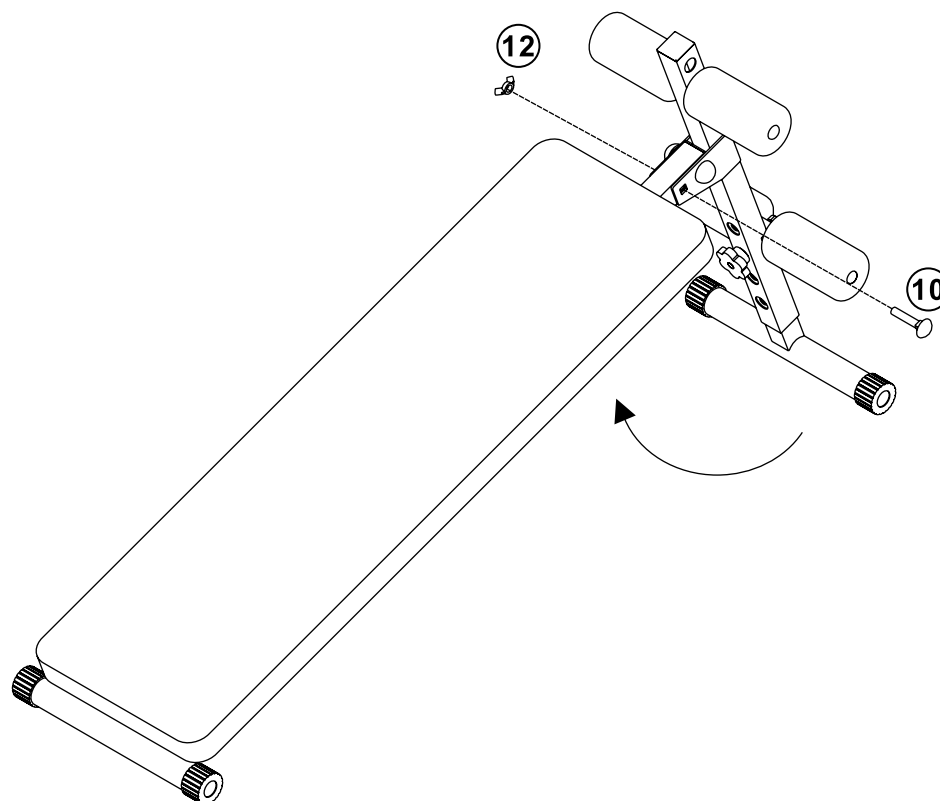
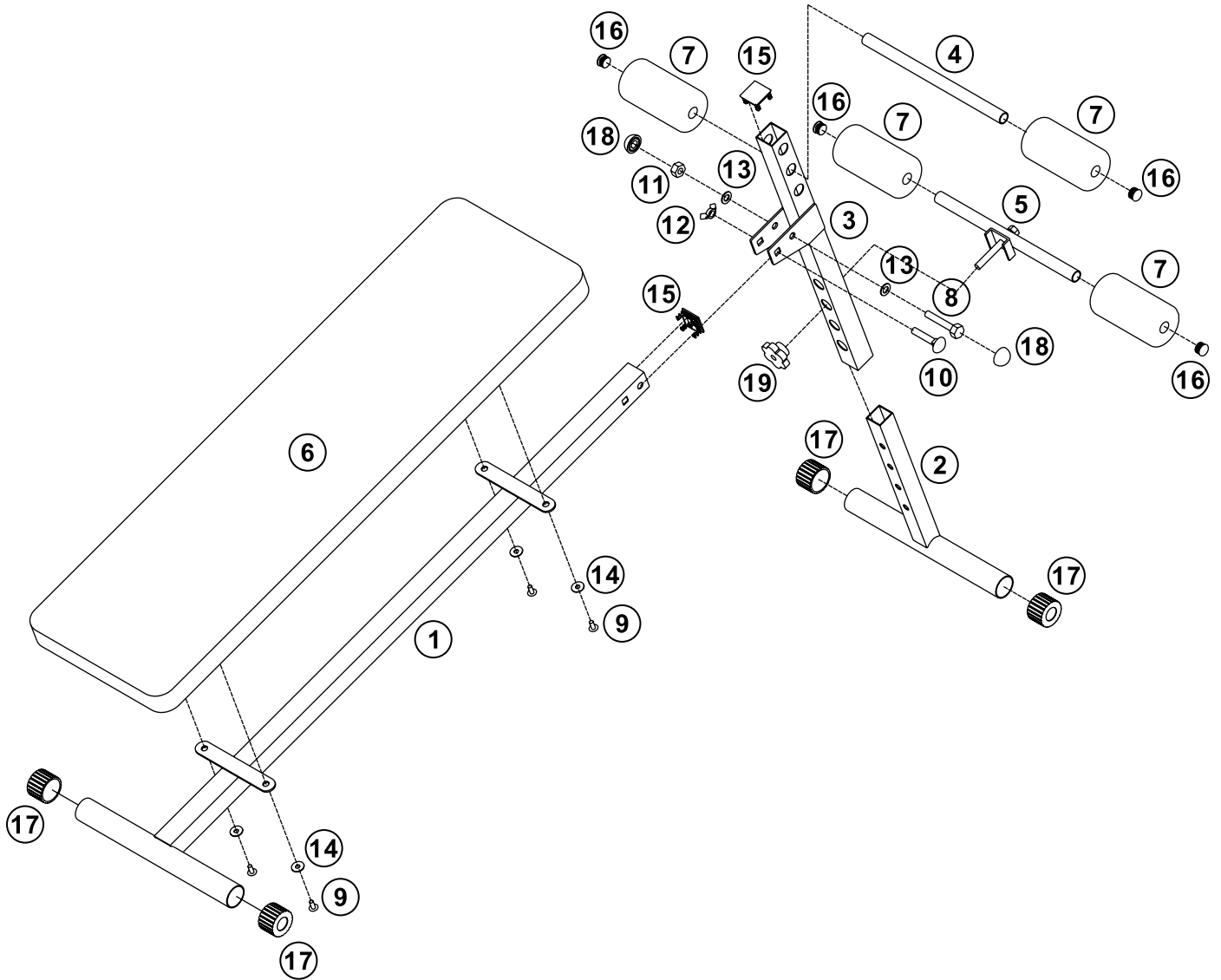

Pieza	Descripción	Canti- dad
1	Barra principal	1
2	Pata de regulación	1
3	Pata frontal	1
4	Barra del apoyo superior	1
5	Barra del apoyo inferior	1
6	Respaldo acolchado	1
7	Rodillo de espuma	4
8	Tornillo M10 de 55 mm	1
9	Tornillo M6 de 15 mm	4
10	Tornillo de fijación M10 de 55 mm	1
11	Contratuerca M10 de nailon	1
12	Tuerca de aletas M10	1
13	Arandela M10	2
14	Arandela M6	4
15	Tapa interior cuadrada de 35 mm	2
16	Tapa interior redonda de 19 mm	4
17	Tapa terminal exterior redonda de 38 mm	4
18	Tapa del tornillo	2
19	Perilla M10	1



Garantía del producto

Este producto cuenta con una garantía para defectos de fabricación de



año

La garantía del producto tiene una validez de doce meses a partir de la fecha de compra original. Si durante este periodo se encuentra algún desperfecto provocado por el uso de materiales defectuosos o por un error de fabricación, siempre que sea posible, el comercio donde adquirió esta unidad se encargará de tramitar su sustitución o reparación gratuitas, o le reembolsará el importe original.

La garantía se rige por las condiciones que se indican a continuación:

- La garantía no cubre los daños accidentales o por uso indebido, las piezas de ferretería, las perillas ni las piezas de desgaste.
- El producto se debe montar y utilizar correctamente y respetando las instrucciones contenidas en el presente manual.
- Debe emplearse únicamente para uso doméstico.
- La reventa del producto y la reparación por parte de personal no cualificado invalidarán la garantía.
- Las especificaciones podrían cambiar sin previo aviso.
- El fabricante no asume ninguna responsabilidad con respecto a posibles daños derivados o consecuentes.
- Esta garantía complementa sus derechos legales, y no los limita en ningún aspecto.

Correo electrónico: Techsupport@RFEinternational.com.

Garante: RFE Europa Ltd
8 Clarendon Drive
Wymbush, Milton Keynes
MK8 8ED, Reino Unido

Justering i sänkt läge

Avlägsna rattbult M10 (19) och tvärstången för benfixering (5). Skjut justeringsbenet (2) upp eller ner tills att bänken har önskad höjd. Montera tillbaka tvärstången för benfixering (5) och rattbult M10 (19) och säkerställ att bulten går igenom både (2) och (3). **OBS!** Höjden på den övre skumrullen kan också justeras genom att avlägsna en skumrulle och föra tillbaka röret.

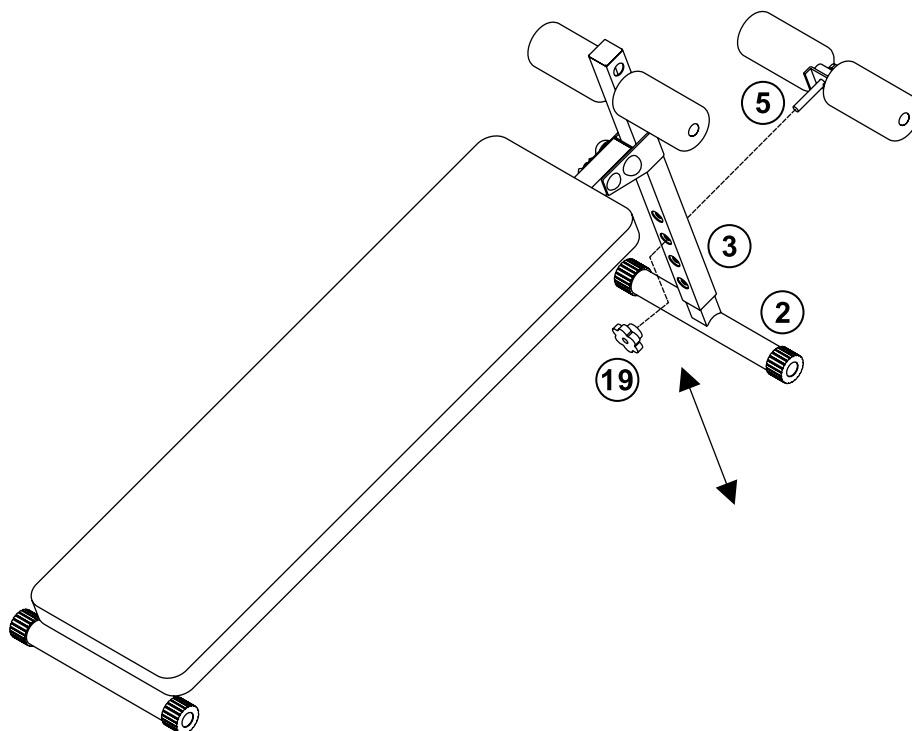

Fäll ihop för förvaring

Avlägsna vingmuttern (12) och bulten (10). Roterar frambenet bakåt tills det når huvudstången. Montera tillbaka vingmuttern och bulten för förvaring.

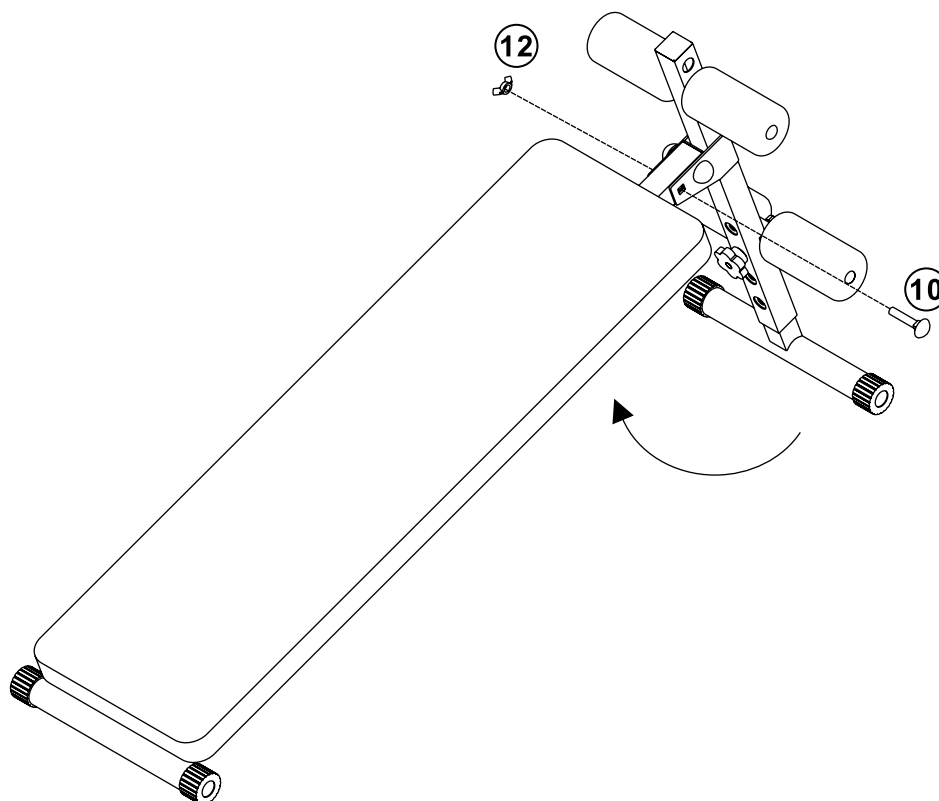

Diagram: artiklar i förstoring

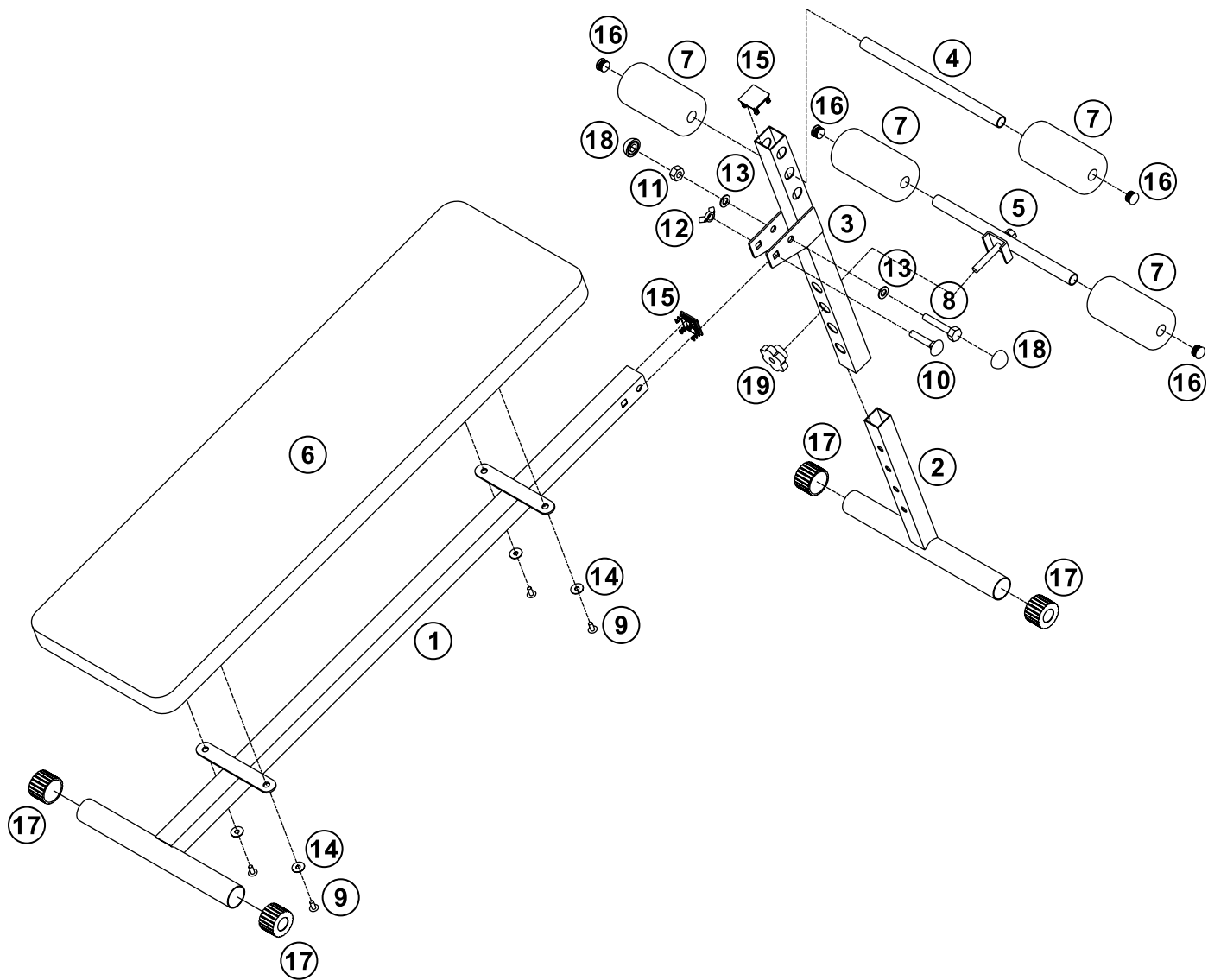

Diagram: lista på artiklar i förstoring



Artikel	Beskrivning	Antal
1	Huvudram	1
2	Justeringsben	1
3	Framben	1
4	Fäströr för skumrulle	1
5	Tvärstång för benfixering	1
6	Dyna	1
7	Skumrulle	4
8	M10 x 55 mm bult	1
9	M6 x 15 mm skruv	4
10	M10 x 55 mm vagnsbult	1
11	M10 nylonlåsmutter	1
12	M10 vingmutter	1
13	M10 bricka	2
14	M6 bricka	4
15	35 mm fyrkantig innerkåpa	2
16	19 mm rund innerkåpa	4
17	38 mm rund, yttre ändkåpa	4
18	Bultkåpa	2
19	Rattbult M10	1



Produktgaranti

Denna produkt är garanterad för tillverkningsfel i



Denna produkt är garanterad i 12 månader efter ursprungligt försäljningsdatum. Defekter som uppstår på grund av felaktiga material eller tillverkningsfel kommer antingen att bytas ut, återbetalas eller repareras kostnadsfritt när så är möjligt under denna period, av den återförsäljare som du köpte enheten från.

Garantin omfattas av följande bestämmelser:

- Garantin täcker inte skador, missbruk, skåpdelar, vreden, eller förbrukningsartiklar.
- Produkten måste vara korrekt installerad och användas i enlighet med instruktionerna i denna handbok.
- Den får endast användas för hemmabruk.
- Garantin ogiltiggörs om produkten säljs vidare eller har skadats vid reparation av osakkunnig person.
- Specifikationerna kan ändras utan föregående avisering.
- Tillverkaren fransäger sig allt ansvar för skador eller följdskador.
- Garantin är i tillägg till, och minskar inte, dina lagstadgade eller juridiska rättigheter.

E-post: Techsupport@RFEinternational.com.

Garantör: RFE Europa Ltd
8 Clarendon Drive
Wymbush, Milton Keynes
MK8 8ED, Storbritannien

Kullanıcı Bilgileri



Açaltma Ayarı

Topuzlu civata M10'u (19) ve bacak çapraz barı çıkarın (5). Gövde arzu edilen yüksekliğe ulaşmaya kadar (2) ayar bacağı yukarı veya aşağı kaydırın. Civatanın (2) ve (3) arasından geçtiğinden emin olarak Bacak çapraz barı (5) ve Topuzlu civata M10'u (19) tekrar takın.

Dikkat: Üst köpük silindiri, ayrıca 1 köpük silindirini çıkararak ve boruyu yeniden konumlandırarak ayarlanabilir.

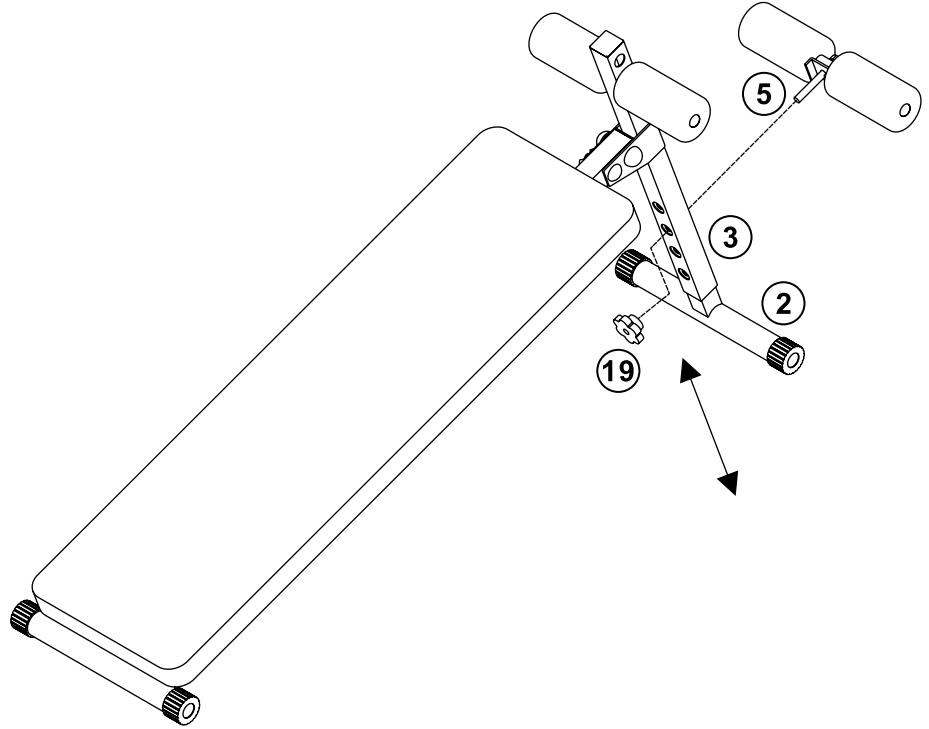

Saklamak için Katla-ma İşlemi

Kelebek somunu (12) ve civatayı çıkarın (10). Ana boruya dokununcaya kadar ön bacağı arkaya doğru döndürün. Saklamak için kelebek somunu ve civatayı yeniden yerleştirin.

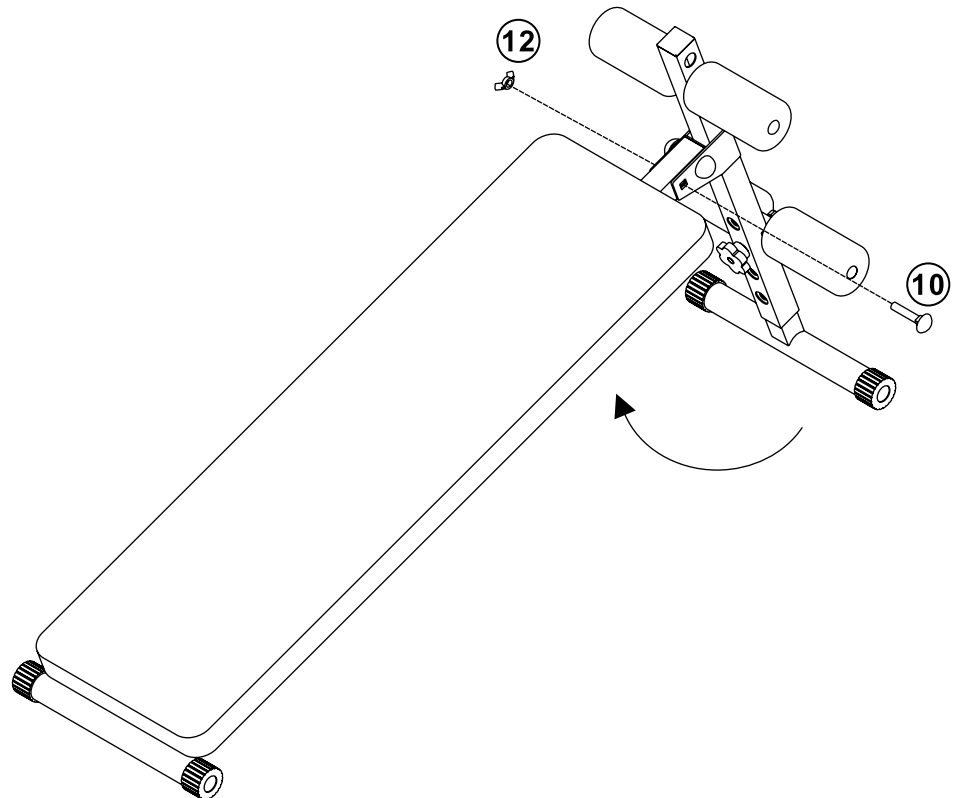

Parça Şeması

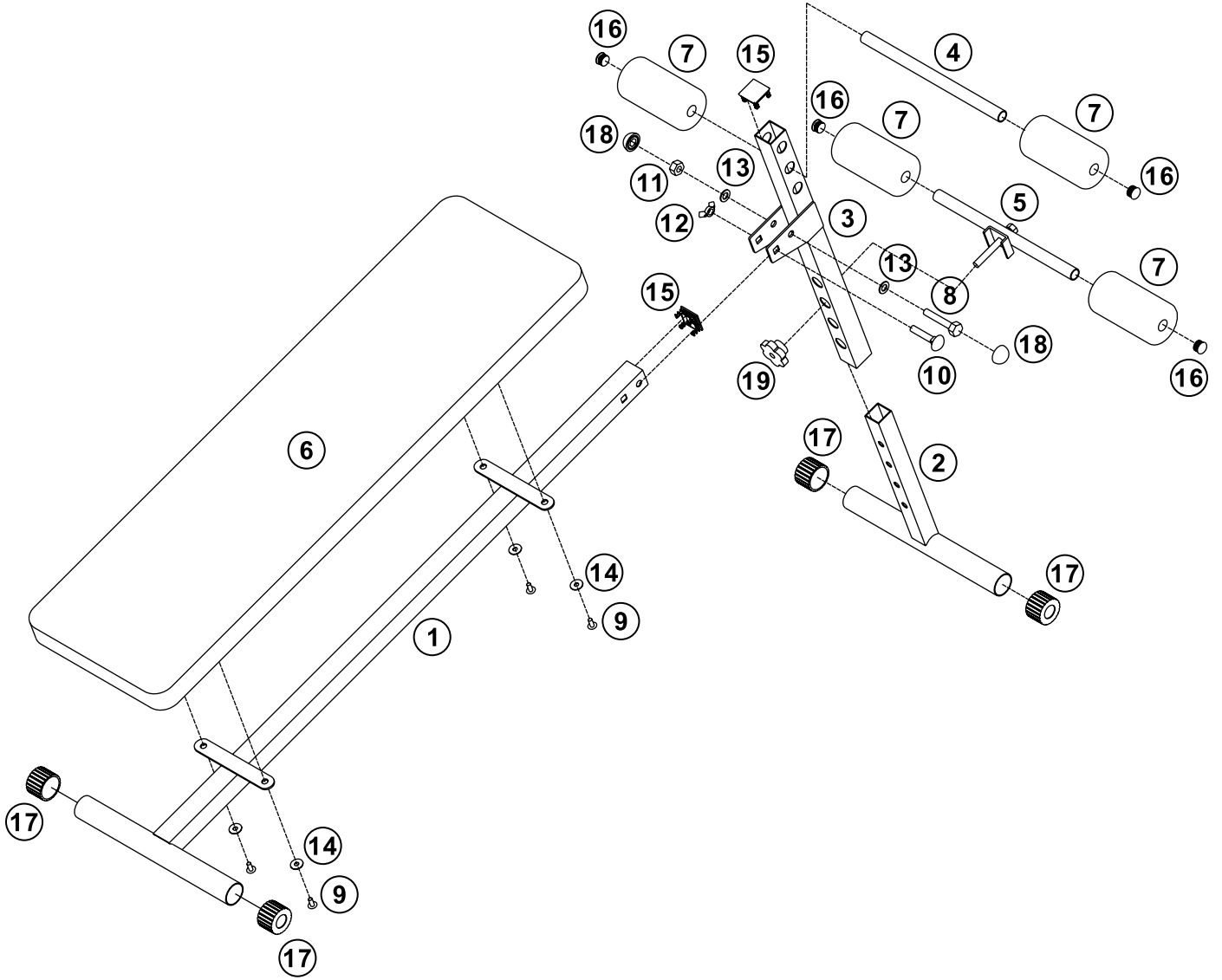

Parça Şeması Listesi



Parça	Açıklama	Miktar
1	Ana gövde	1
2	Ayar bacağı	1
3	Ön bacak	1
4	Köpük montaj borusu	1
5	Bacak çapraz bar	1
6	Kaplama	1
7	Köpük silindir	4
8	M10 x 55 mm Cıvata	1
9	M6 x 15 mm Vida	4
10	M10 x 55 mm Ağaç cıvatası	1
11	M10 Naylon kilit somunu	1
12	M10 Kelebek somun	1
13	M10 Conta	2
14	M6 Conta	4
15	35 mm Kare gömülü kapak	2
16	19 mm Yuvarlak gömülü kapak	4
17	38 mm Yuvarlak dış uç kapak	4
18	Yuvarlak başlı cıvata	2
19	Topuzlu cıvata M10	1



Ürün Garantisi

This product is guaranteed against manufacturing defects for a period of



Bu ürün, satın alınma tarihinden itibaren on iki ay boyunca garanti kapsamındadır. Kusurlu malzemeler veya işçilik nedeniyle oluşan herhangi bir kusur, mümkün olan durumlarda üniteyi satın aldığınız bayi tarafından bu süre içerisinde ücretsiz olarak değiştirilecek, para iadesi yapılacak veya tamir edilecektir.

Garanti, aşağıdaki koşullara tabidir:

- Bu garanti, kazayla oluşan hasar, hatalı kullanım, dolap parçaları, topuz veya sarf malzemelerini kapsamaz.
- Ürün, bu kitapçıkta yer alan talimatlara uygun olarak düzgünce kurulmalı ve çalıştırılmalıdır.
- Sadece evde kullanım içindir.
- Ürünün tekrar satılması veya deneyimsiz bir onarma işlemi yüzünden hasar görmesi durumunda garanti geçersiz hale gelecektir.
- Özellikler, haber vermeden değişime tabidir.
- Üretici, kazara veya dolaylı hasar için herhangi bir yükümlülüğü reddeder.
- Garanti, yasal veya kanuni haklarınıza ek olarak sunulur ve yasal veya kanuni haklarınızı azaltmaz.

E-posta: Techsupport@RFEinternational.com.

Garantör: RFE Europa Ltd
8 Clarendon Drive
Wymbush, Milton Keynes
MK8 8ED, UK

- In the event of a problem with the product within the guarantee period call the **Customer Helpline: 0800 440 2459.**
- 质保期内，一旦产品出现问题，请拨打客户热线：**0086-411-82766207**。
- I tilfælde af et problem med produktet inden for garantien kan du ringe til **Kundehjælpelinjen: +45 2859 1998.**
- Mikäli tuotteessa ilmenee ongelma takuuajan kuluessa, soita **Asiakaspalveluun: +45 2859 1998.**
- Si vous rencontrez un problème avec le produit pendant la période de garantie, veuillez appeler notre **Assistance téléphonique client : +33 (0)171 82 84 99.**
- Im Falle eines Problems mit dem Produkt innerhalb des Garantiezeitraums rufen Sie bitte folgende Nummer an **Kundendienst: +49 (0) 6431 58463-0.**
- Σε περίπτωση προβλήματος με το προϊόν εντός της περιόδου εγγύησης, τηλεφωνήστε στη **Γραμμή Βοήθειας Πελατών: +30 210 2758228.**
- In caso di problemi con il prodotto durante il periodo di garanzia, contattare il numero di **Assistenza Clienti: +49 (0) 6431 58463 13.**
- In het geval van een probleem met het product binnen de garantieperiode, neemt u Contact op met **de klantenservice: +49 (0)6 431 58 4630.**
- Ved et problem med produktet innen garantiperioden ring **Kundeservice: +45 2859 1998.**
- Caso ocorra algum problema com o produto durante a garantia, contacte a **Linha de Apoio a Clientes: +35 1 96 10 14 778.**
- Si experimenta algún problema con el producto dentro del plazo de garantía, puede contactar con nosotros a través de: **Teléfono de atención al cliente: +34 800 600 816.**
- Om problem med produkten uppstår under garantiperioden, kontakta **Kundtjänst: +46 (0)40-303144.**
- Garanti süresi içinde ürünle ilgili herhangi bir sorun yaşanması durumunda, şu Numarayı arayınız: **Müşteri Yardım Hattı: +90 212 8757901.**