

SL7021

Hack Squat

OWNER'S MANUAL

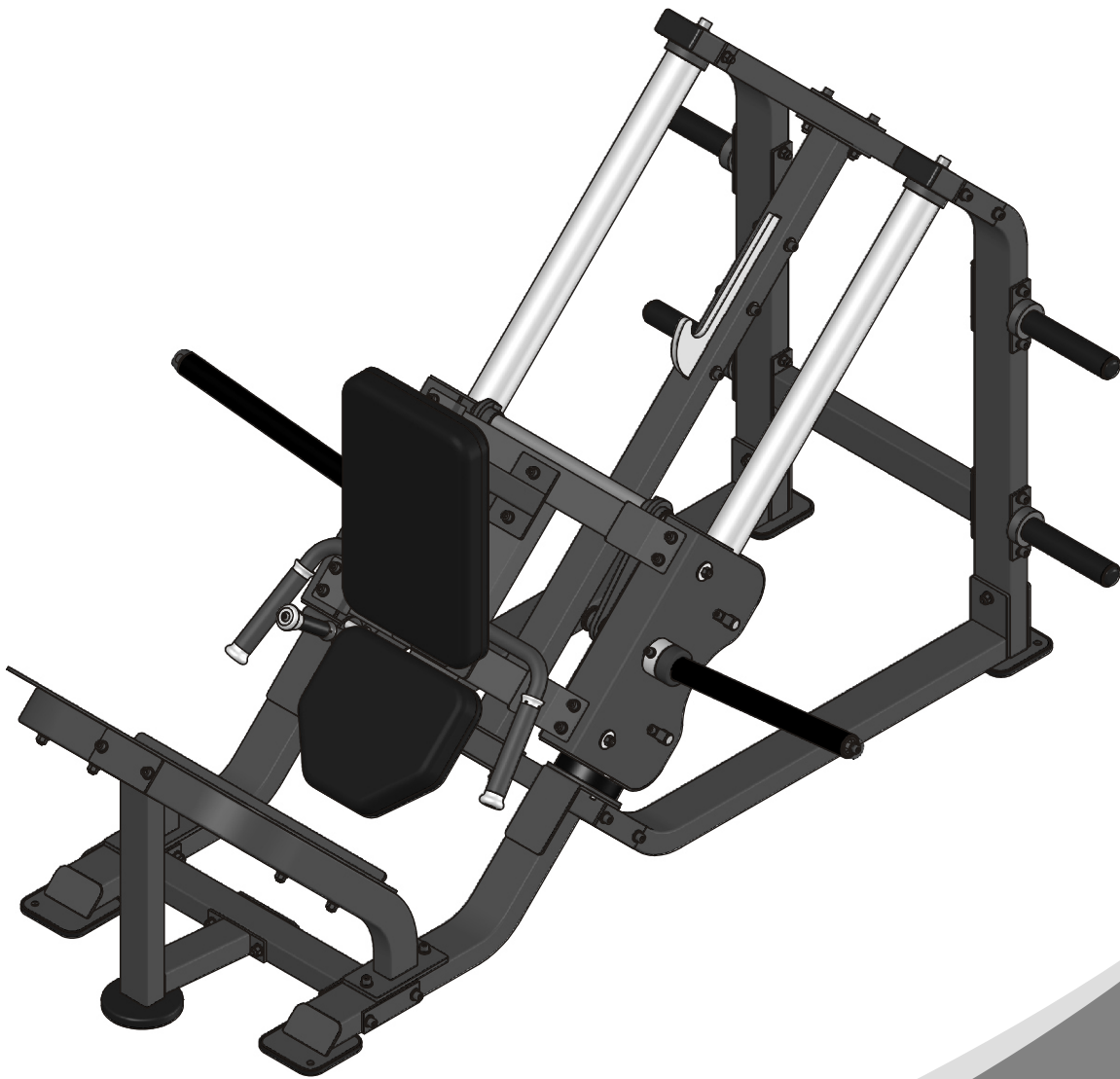

! CAUTION

Read all precautions
and instructions in this manual
before using this equipment

! CAUTION

Read all precautions and instructions in this manual before using this equipment.

Table Of Contents

Important Safety Instructions----- 3

Instructions----- 5

Parts List and Exploded View----- 6

Measurement Guide----- 19

Assembly Instructions----- 20

Assembly----- 21

Adjust Instructions-----32

Exercise Instructions-----33

Maintenance Schedule----- 34

General Maintenance Information----- 35

Weight Training Tips----- 36

Important Safety Instructions

Before beginning any fitness program, you should obtain a complete physical examination from your physician. When using exercise equipment, basic precautions should always be taken, including the following:

1. Read all instructions before using the equipment.
These instructions are written to ensure your safety and to protect the unit.
2. Use the equipment only for its intended purpose as described in this guide.
Do not use accessory attachments that are not recommended by the manufacturer: such attachments might cause injuries.
3. The product should only be used on a level surface and is with 0.5 meters space around the product.
Do not use the equipment outdoors.
4. Do not allow children on or near the equipment. And children are not allowed to use this equipment.
Teenagers should use this equipment with adult supervision.
5. Do not overexert yourself or work to exhaustion.
Do not attempt to lift more weight than you can control safely.
If you feel any pain or abnormal symptoms, stop your workout immediately and consult your physician.
6. This equipment is not used as medical apparatus and instruments.
7. Never operate the unit when it has been dropped or damaged.
Never drop or insert anything into any opening in the equipment.
Always check the unit and its cables before each use. Make sure that all fasteners and cables are secure and in good working condition.
Frayed or worn cables can be dangerous and may cause injury. Periodically check these cables for any indication of wear.
Keep hands, limbs, loose clothing and long hair well out of the way of moving parts.
8. Be careful when getting on or off the equipment.
9. Wear proper exercise clothing and shoes for your workout, no loose clothing.

Important Safety Instructions

Personal Safety During Assembly

Read each step in the assembly instructions and follow the steps in sequence. Do not skip ahead. If you skip ahead, you may learn later that you have to disassemble components and that you may have damaged the equipment.

Assemble and operate the equipment on a solid, level surface. Locate the unit a few feet from walls or furniture to provide easy access. The equipment is designed for your enjoyment. By following these precautions and using common sense, you will have many safe and pleasurable hours of healthful exercise with the equipment.

Training Area and Free Area

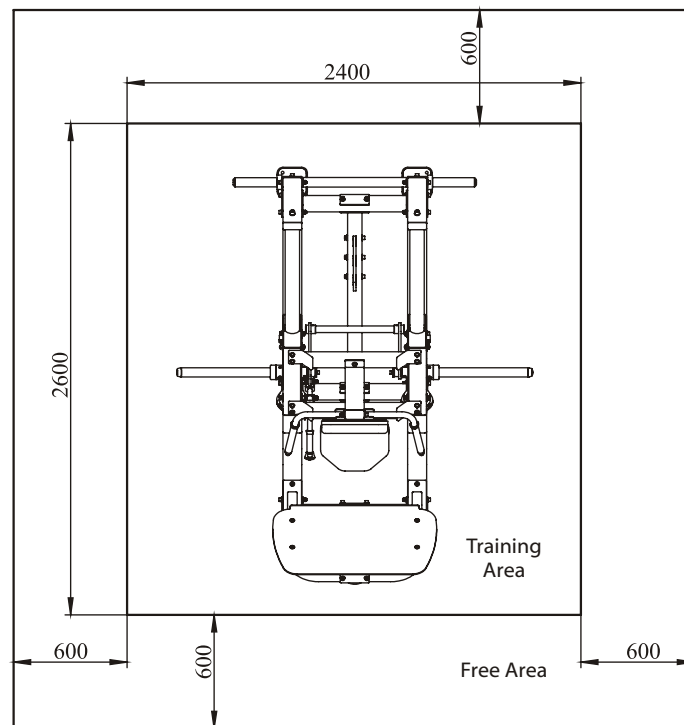

Specifications

Class: S

Maximum Wt. Capacity: 400kg/ 880lbs

Maximum User Weight: 150kg/ 330lbs

Product Total Surface: 1888*2210mm

Product Total Mass: 235.5kg/ 519lbs

Instructions

Before beginning assembly please take the time to read instructions thoroughly. Please use the various lists in this manual to make sure that all parts have been included in your shipment. When ordering, use part number and description from the lists. Use only our replacement part when servicing. Failure to do so will void your warranty and could result in personal injury.

The equipment is designed to provide the smoothest, most effective exercise motion possible. After assembly, you should check all functions to ensure correct operation. If you experience problems, first recheck the assembly instructions to locate any possible errors made during assembly. If you are unable to correct the problem, call your authorized dealer. Be sure to have your serial number and this manual when calling. When all parts have been accounted for, continue on.

Tools Required



Ratchet Wrench and Socket



Adjustable Wrench



Rubber Mallet



Hex Key Wrench Set



Phillips Screwdriver

Exploded View and Parts List

Left Bottom Frame ASSY

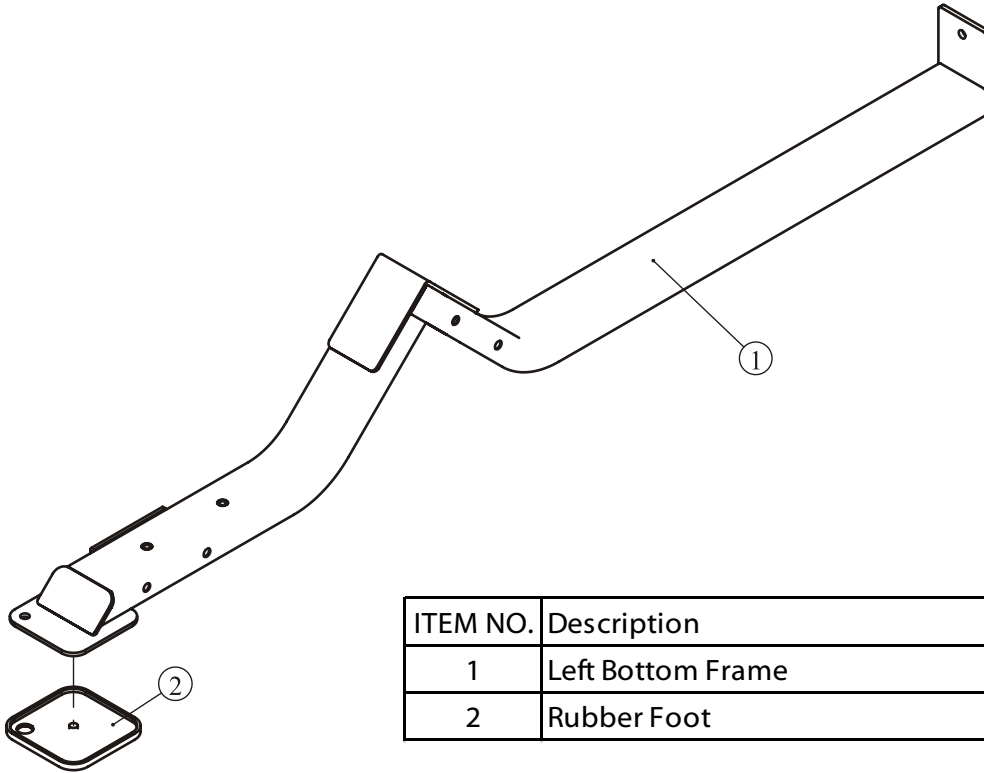

ITEM NO.	Description	QTY
1	Left Bottom Frame	1
2	Rubber Foot	1

Right Bottom Frame ASSY

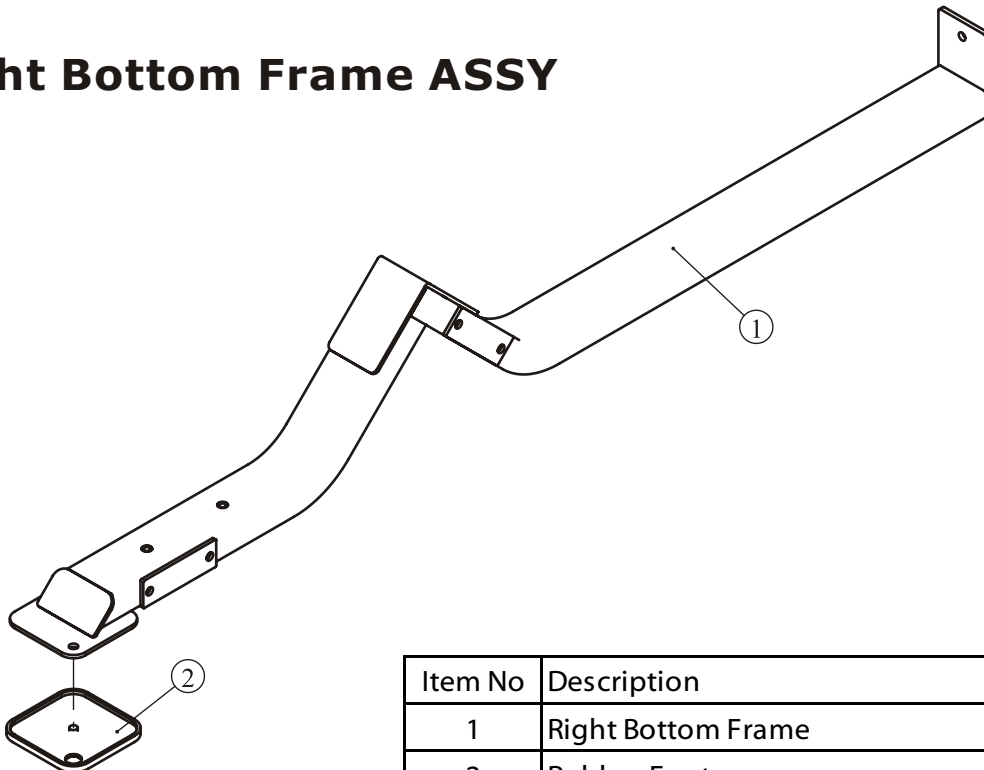

Item No	Description	Qty
1	Right Bottom Frame	1
2	Rubber Foot	1

Exploded View and Parts List

Left Union Frame ASSY

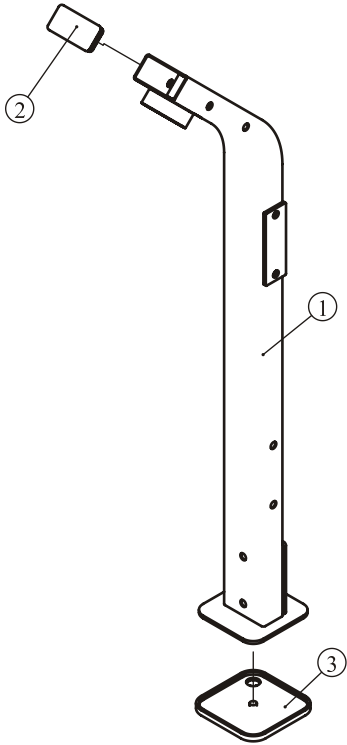

Item No	Description	Qty
1	Left Union Frame	1
2	Plug □ 50*100	1
3	Rubber Foot	1

Right Union Frame ASSY

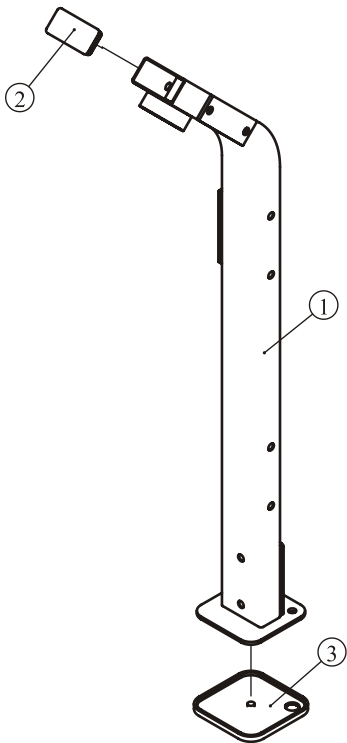

Item No	Description	Qty
1	Right Union Frame	1
2	Plug □ 50*100	1
3	Rubber Foot	1

Exploded View and Parts List

Arm Pad Frame ASSY

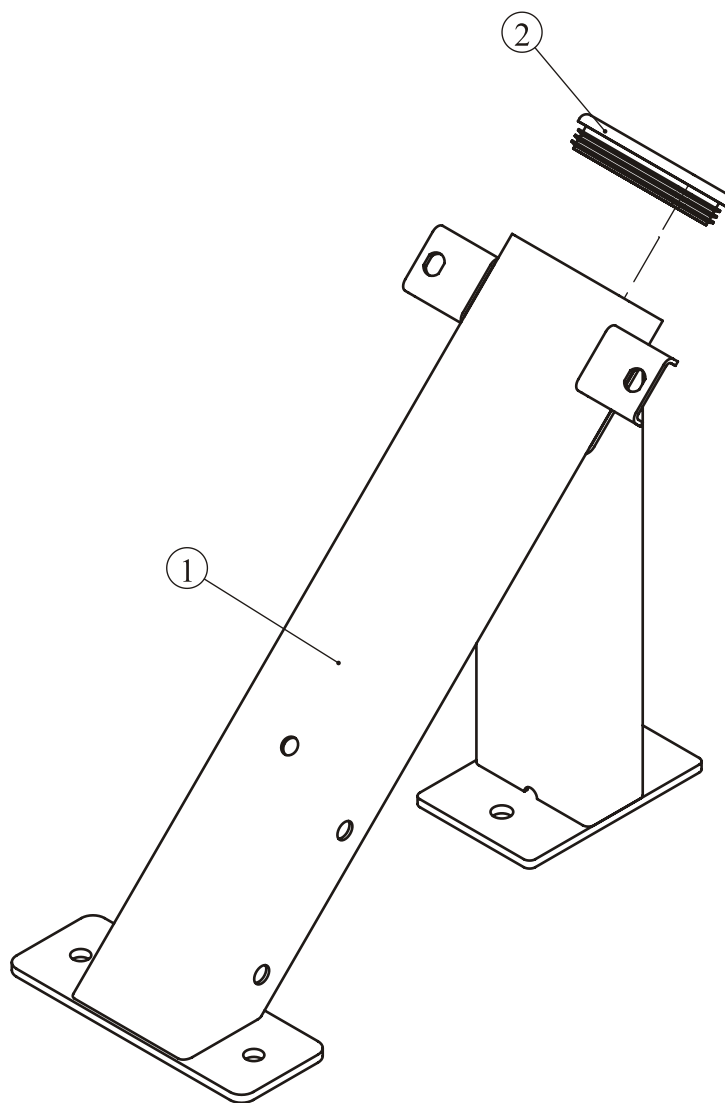

Item No	Description	Qty
1	Arm Pad Frame	1
2	Plug □ 50*100	1

Exploded View and Parts List

Left Handle ASSY

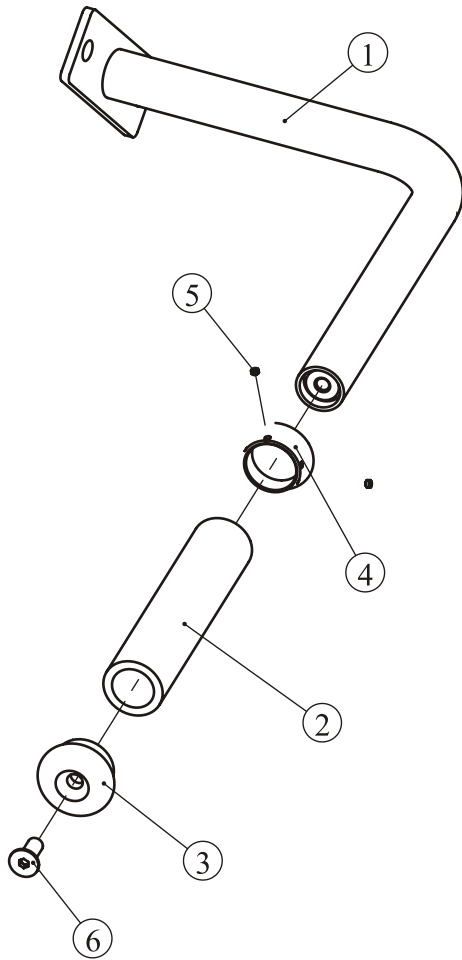

Right Handle ASSY

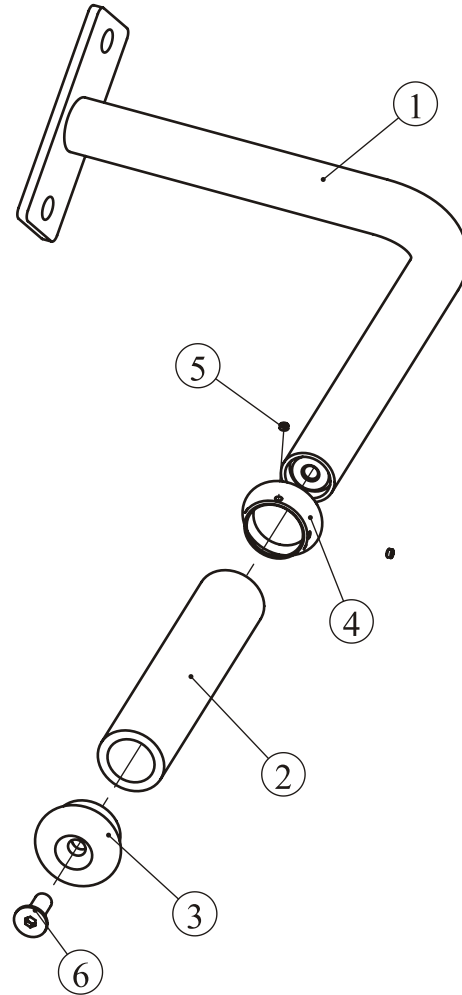

ItemNo	Description	Qty
1	Left Handle	1
2	Handle Casing	1
3	Aluminium Cap Φ 32	1
4	Aluminium Ring Φ 32	1
5	Socket Set Screw 10-32*3.2	2
6	Flat Head Cap Screw M10*25	1

ItemNo	Description	Qty
1	Right Handle	1
2	Handle Casing	1
3	Aluminium Cap Φ 32	1
4	Aluminium Ring Φ 32	1
5	Socket Set Screw 10-32*3.2	2
6	Flat Head Cap Screw M10*25	1

Exploded View and Parts List

Middle Connection Frame ASSY

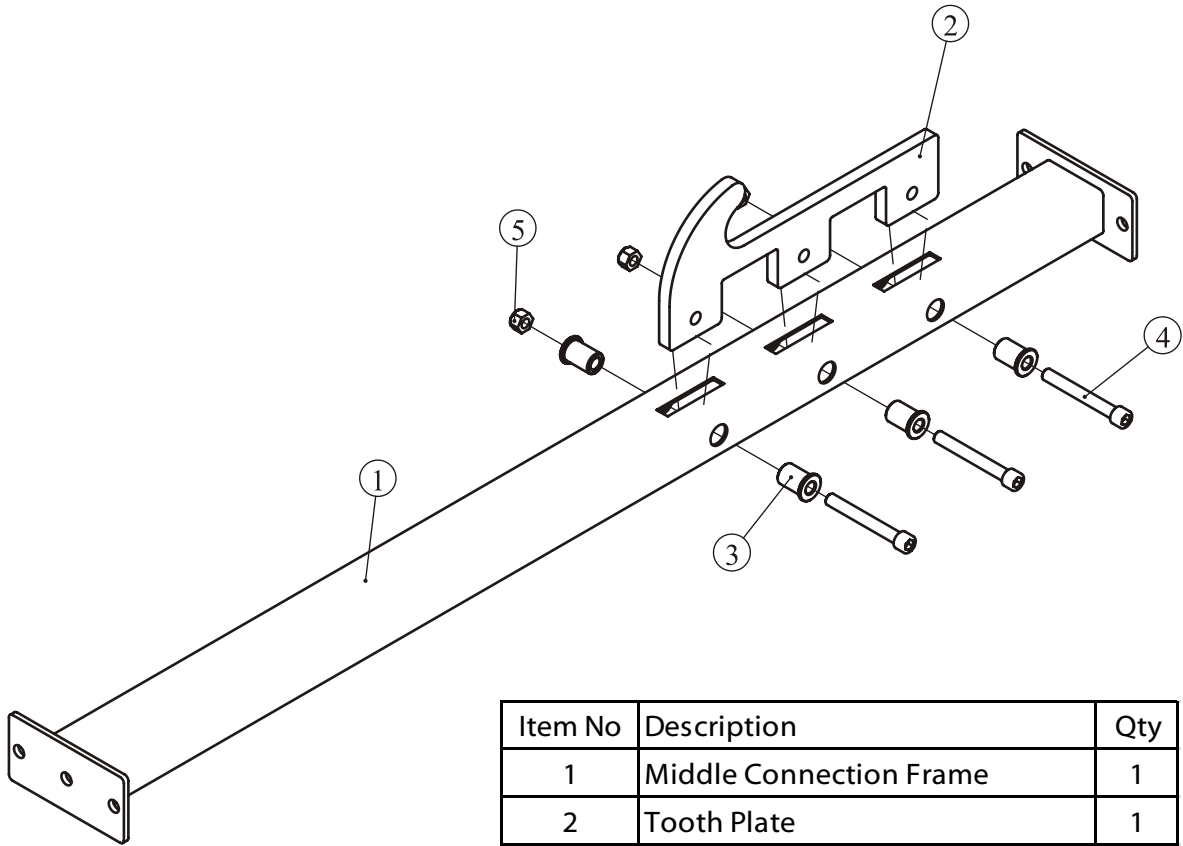

Item No	Description	Qty
1	Middle Connection Frame	1
2	Tooth Plate	1
3	Small Bush	6
4	Socket Head Cap Screw M12*95	3
6	Nylon Lock Nut M12	3

Link Frame ASSY

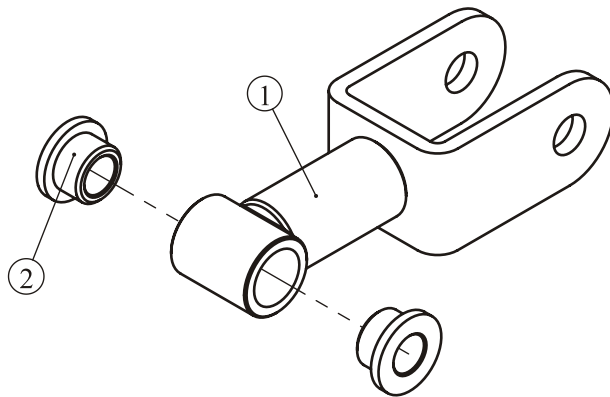

Item No	Description	Qty
1	Link Frame	1
2	Bush	2

Exploded View and Parts List

Adjustable Handle Frame ASSY

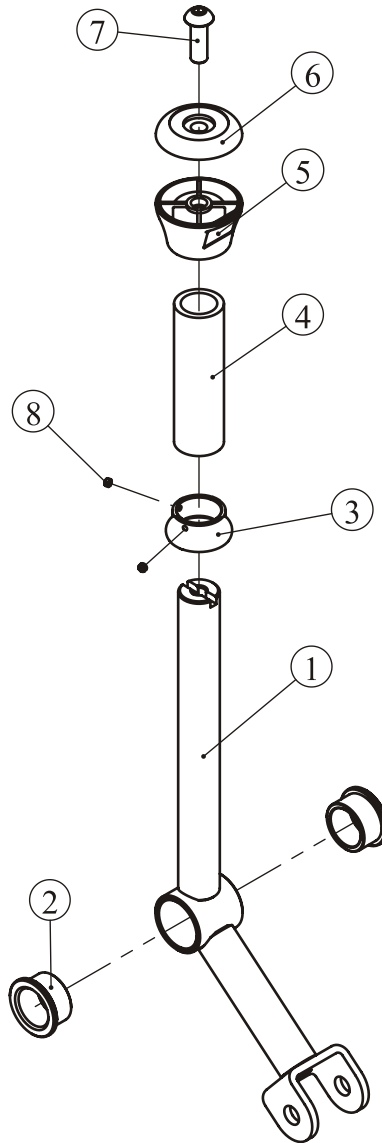

Item No	Description	Qty
1	Adjustable Handle Frame	1
2	Copper Bearing	2
3	Aluminium Ring Φ 25	1
4	Handle Casing	1
5	Plastic Head Holder	1
6	Plastic Seal Bonnet	1
7	Button Head Cap Screw 3/8-16*32	1
8	Socket Set Screw 10-32*3.2	2

Exploded View and Parts List

Left Extend Frame ASSY

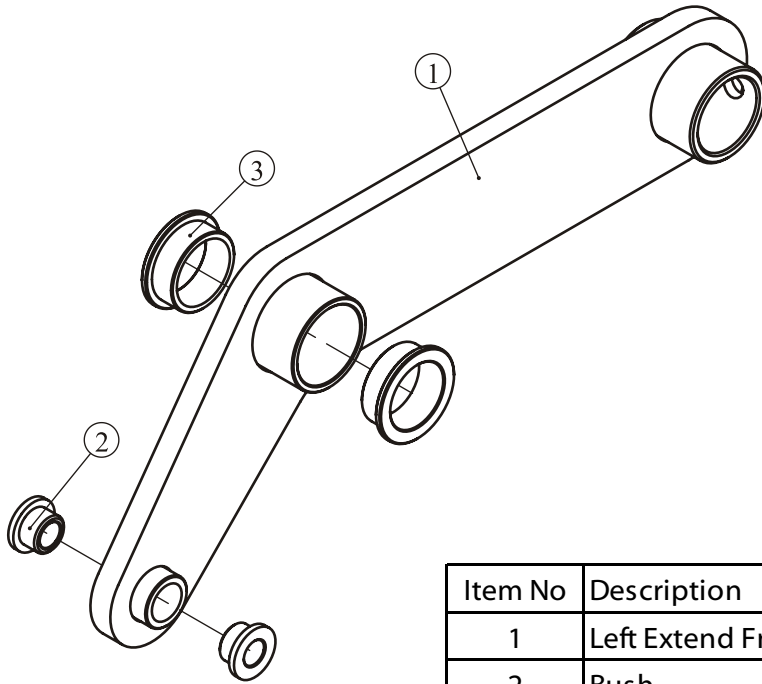

Item No	Description	Qty
1	Left Extend Frame	1
2	Bush	2
3	Copper Bearing	2

Right Extend Frame ASSY

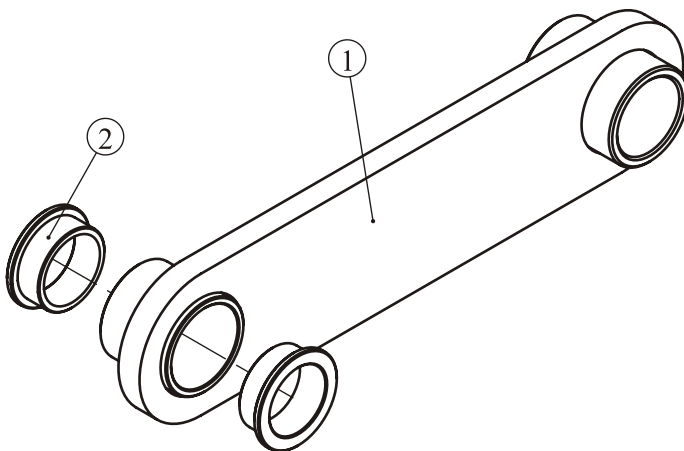

Item No	Description	Qty
1	Right Extend Frame	1
2	Copper Bearing	2

Exploded View and Parts List

Connection Frame ASSY

Item No	Description	Qty
1	Connection Frame	1
2	Plug □ 50*100	1

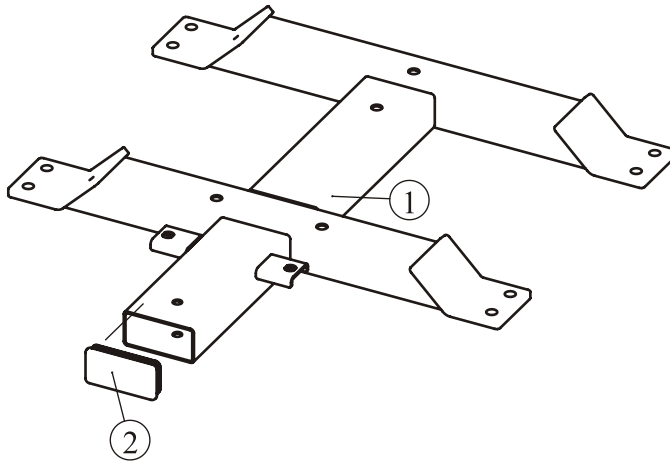

Weight Horn ASSY

Item No	Description	Qty
1	Weight Horn	1
2	Barbell sleeve	1
3	Cap	1
4	Socket Head Cap Screw M12*35	1
5	Flat Washer $\Phi 13*\Phi 24*2.5$	1

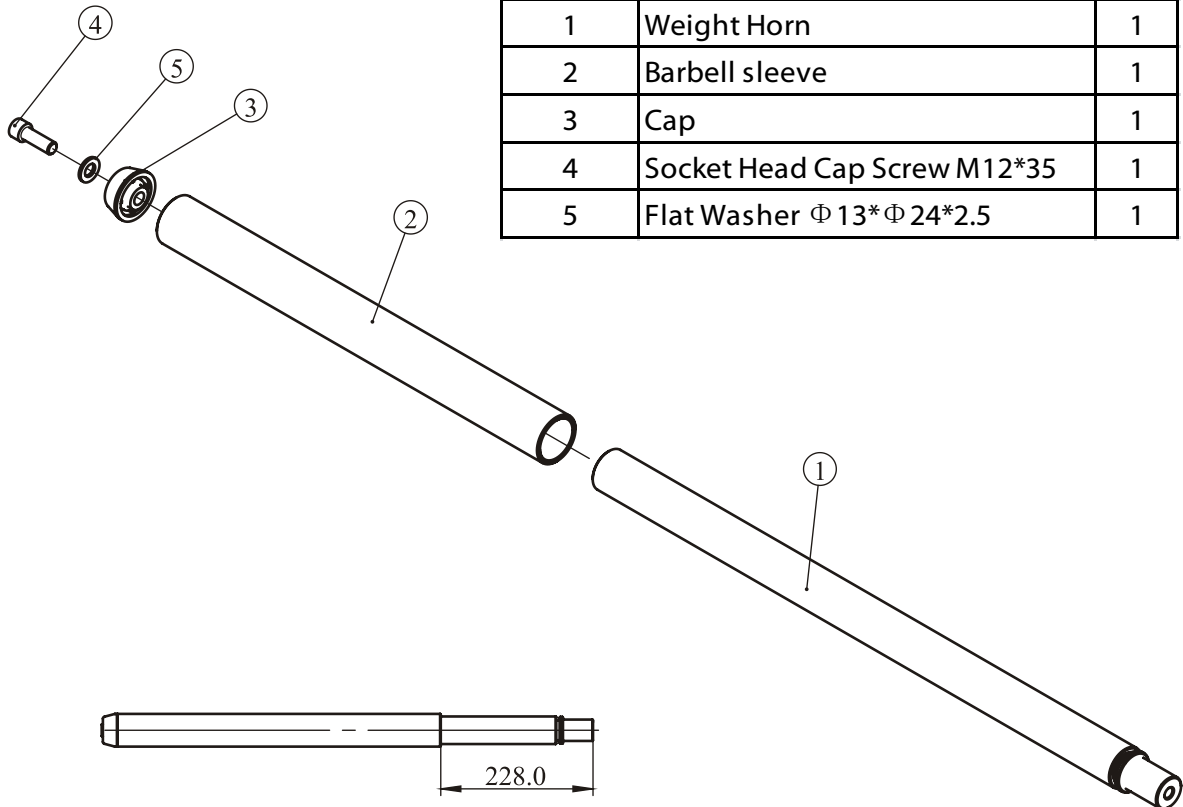

Exploded View and Parts List

Left Idler Wheel Frame ASSY

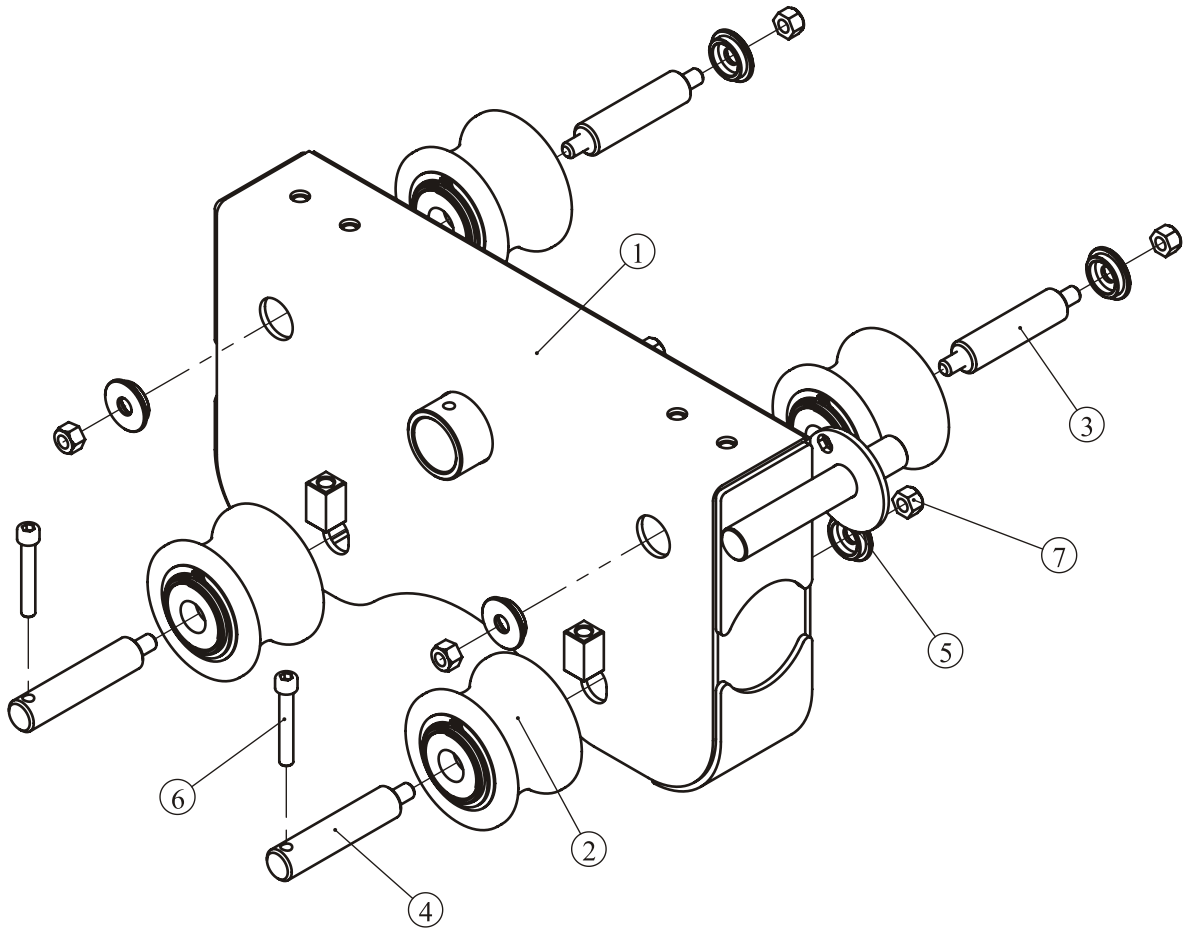

Item No	Description	Qty
1	Left Idler Wheel Frame	1
2	Roller	4
3	Externally Threaded Sshaft	2
4	Internal Threaded Shaft	2
5	Bush	6
6	Socket Head Cap ScrewM10*65	2
7	Nylon Lock Nut M12	6

Exploded View and Parts List

Right Idler Wheel Frame ASSY

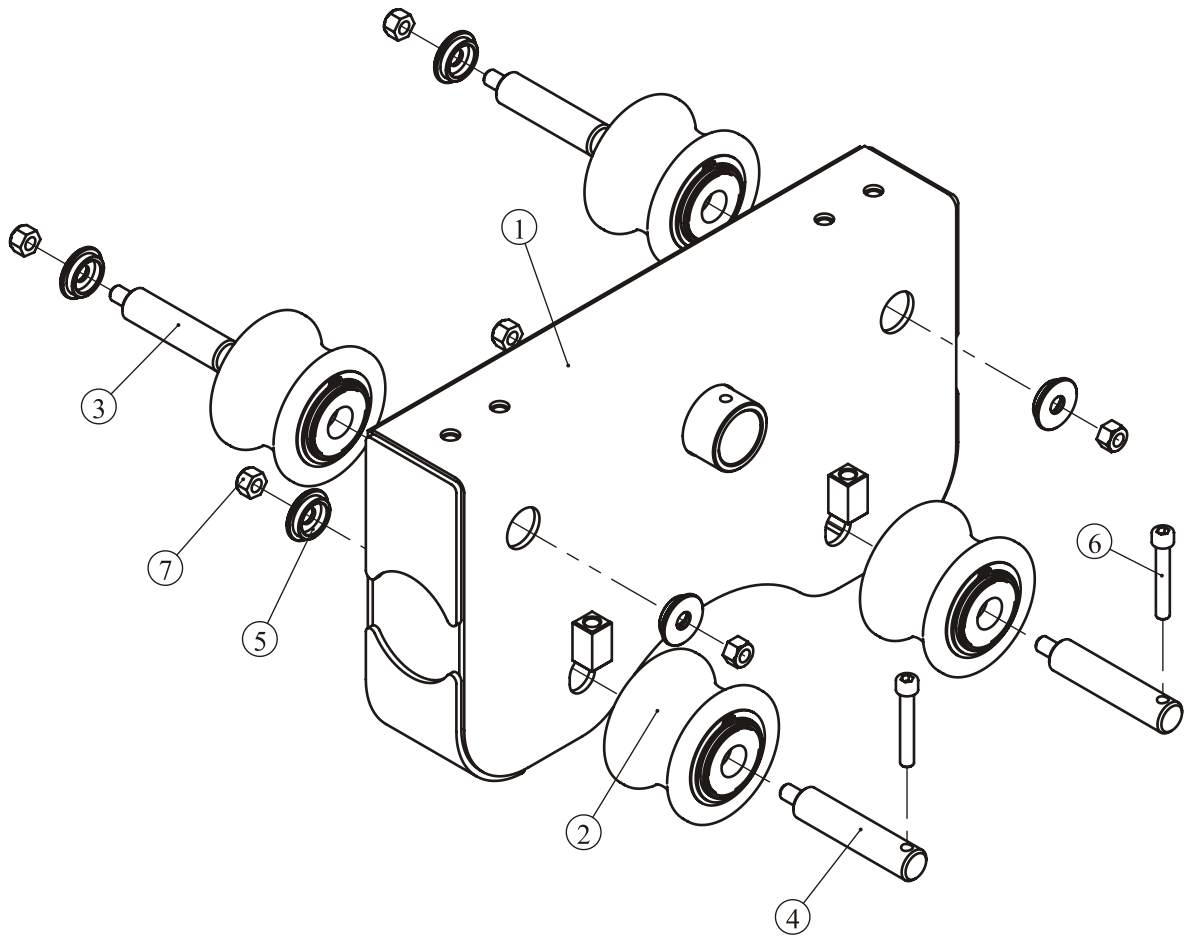

Item No	Description	Qty
1	Right Idler Wheel Frame	1
2	Roller	4
3	Externally Threaded Sshaft	2
4	Internal Threaded Shaft	2
5	Bush	6
6	Socket Head Cap Screw M10*65	2
7	Nylon Lock Nut M12	6

Exploded View and Parts List

Small Limit Frame ASSY

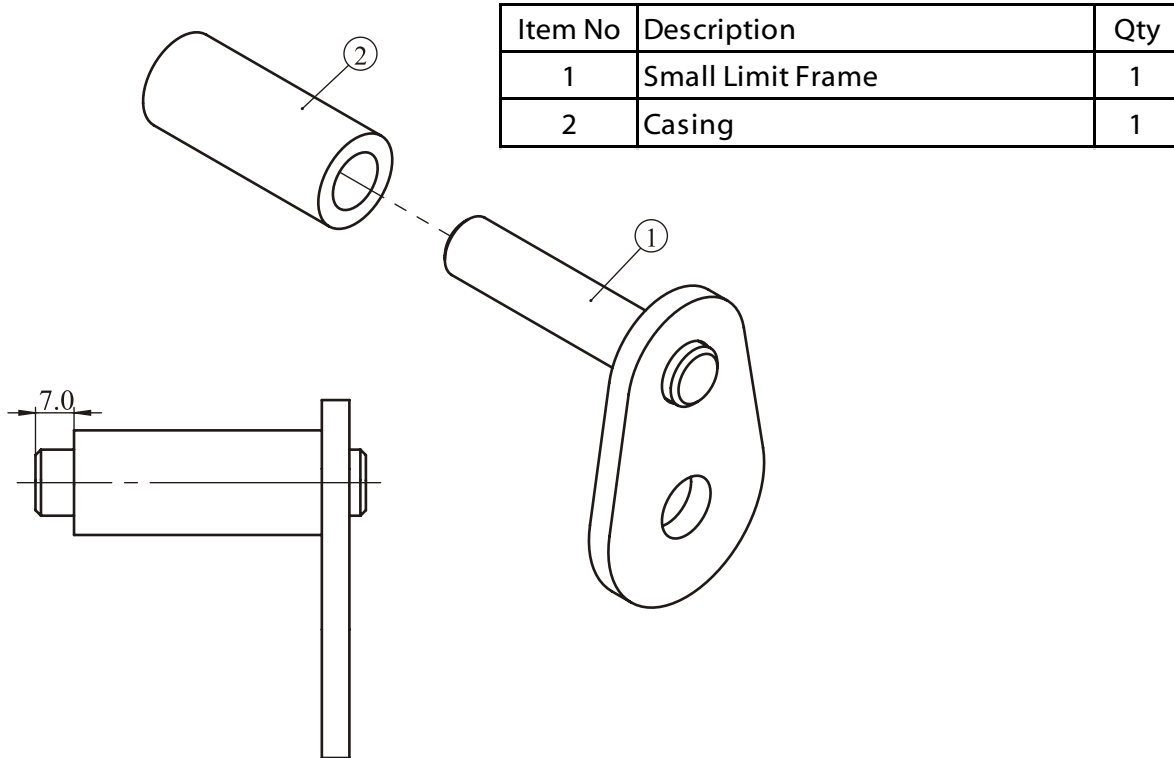

Weight Plate Storage ASSY

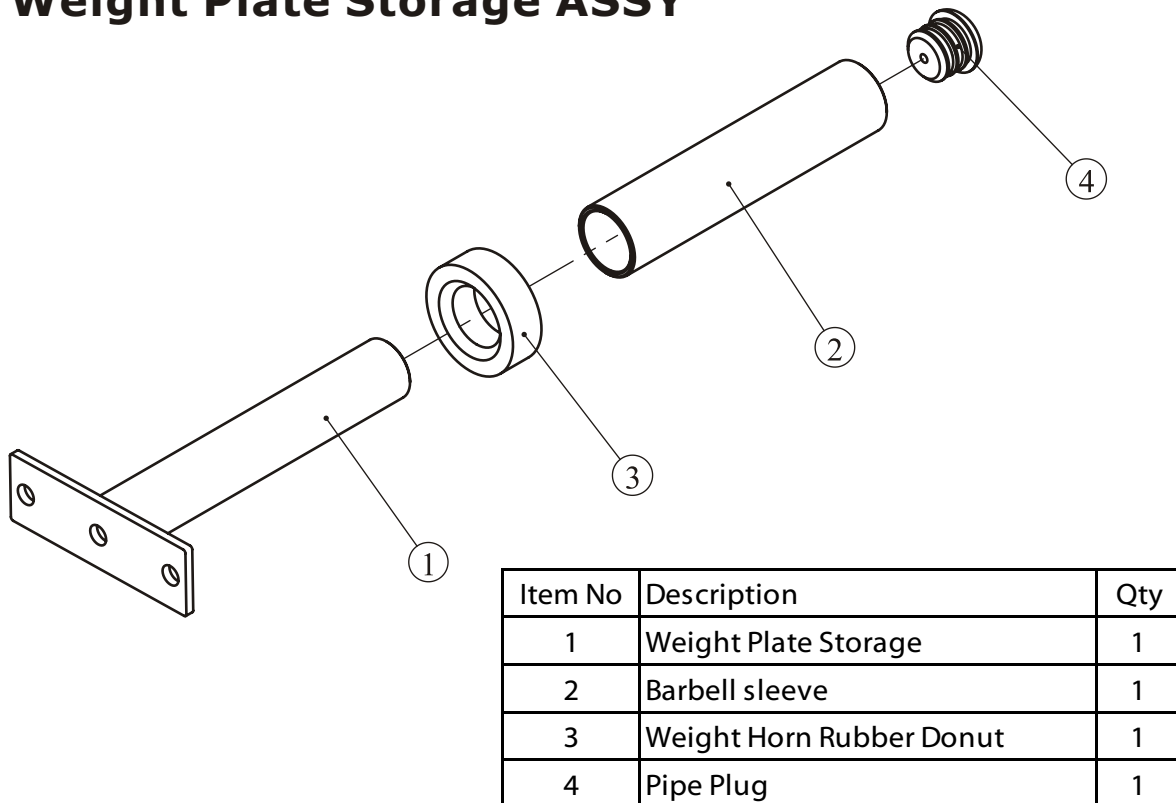

Exploded View and Parts List

Overall

ITEM NO.	Description	QTY	ITEM NO.	Description	QTY
1	Left Bottom Frame Assembly	1	31	Affixed Frame	1
2	Right Bottom Frame Assembly	1	32	External Fixation Plate	1
3	Left Union Frame Assembly	1	33	Weight Horn Rubber Donut	2
4	Right Union Frame Assembly	1	34	Flat Washer $\Phi 50.8 * \Phi 13.5 * 3$	2
5	Upper Beam Frame	2	35	Socket Head Cap Screw M16*100	2
6	Lower Beam Frame	1	36	Socket Head Cap Screw M12*135	22
7	Before Connecting Frame	1	37	Socket Head Cap Screw M12*110	2
8	Pedal Bracket	1	38	Socket Head Cap Screw M12*85	10
9	Left Foot Frame	1	39	Socket Head Cap Screw M12*75	4
10	Right Foot Frame	1	40	Socket Head Cap Screw M12*70	2
11	Foot Checkered	1	41	Socket Head Cap Screw M12*30	15
12	Arm Pad Frame Assembly	1	42	Socket Head Cap Screw M10*75	2
13	Left Handle Assembly	1	43	Socket Head Cap Screw M10*25	4
14	Right Handle Assembly	1	44	Socket Head Cap Screw M10*20	2
15	Middle Connection Frame Assembly	1	45	Flat Head Cap Screw M12*100	4
16	Link Frame Assembly	1	46	Flat Head Cap Screw M10*20	6
17	Adjustable Handle Frame Assembly	1	47	Socket Set Screw M10*8	2
18	Left Extend Frame Assembly	1	48	Nylon Lock Nut M12	42
19	Right Extend Frame Assembly	1	49	Flat Washer $\Phi 28 * \Phi 16.5 * 2$	2
20	Connection Frame Assembly	1	50	Flat Washer $\Phi 13 * \Phi 24 * 2.5$	95
21	Lead Rail Assembly	2	51	Flat Washer $\Phi 11 * \Phi 20 * 2$	8
22	Weight Horn Assembly	2	52	Split Lock Washer $\Phi 12$	2
23	Left Idler Wheel Frame Assembly	1	53	Hex Key S=5	1
24	Right Idler Wheel Frame Assembly	1	54	Hex Key S=6	1
25	Small Limit Frame Assembly	1	55	Hex Key S=8	1
26	Limit Shaft $\phi 35$	1	56	Hex Key S=10	1
27	Large Rubber Bumper	2	57	Hex Key S=12	1
28	Arm Pad	1	58	Socket Head Cap Screw M10*30	2
29	Seat Pad	1	59	Split Lock Washer $\Phi 10$	2
30	Weight Plate Storage	4			

Exploded View and Parts List

Overall

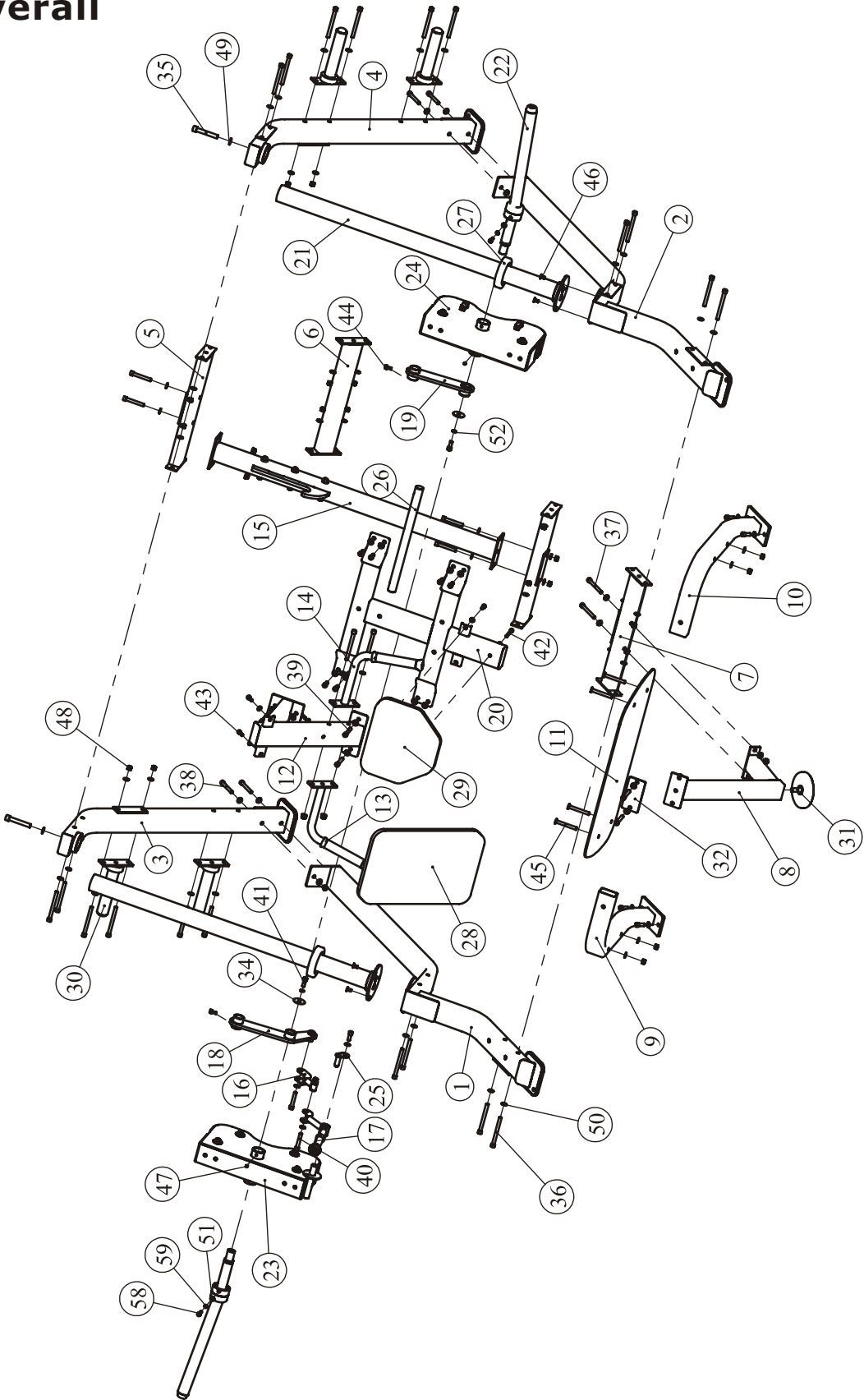

Measurement Guide

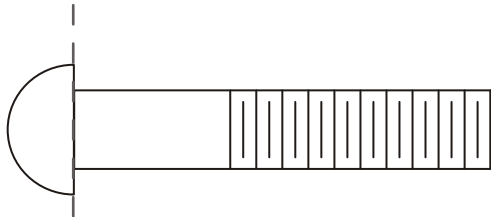

BHCS = Button Head Cap Screw

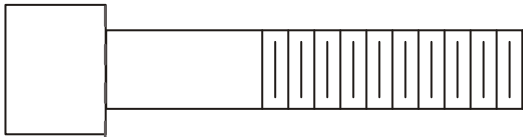

SHCS = Socket Head Cap Screw

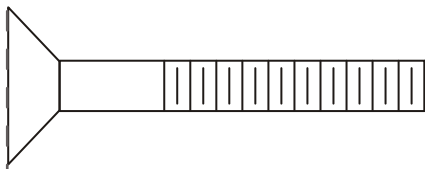

FHCS = Flat Head Cap Screw

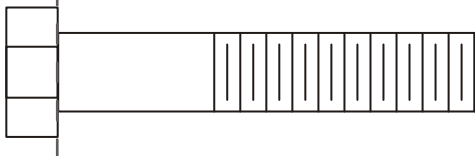

HHB = Hex Head Bolt

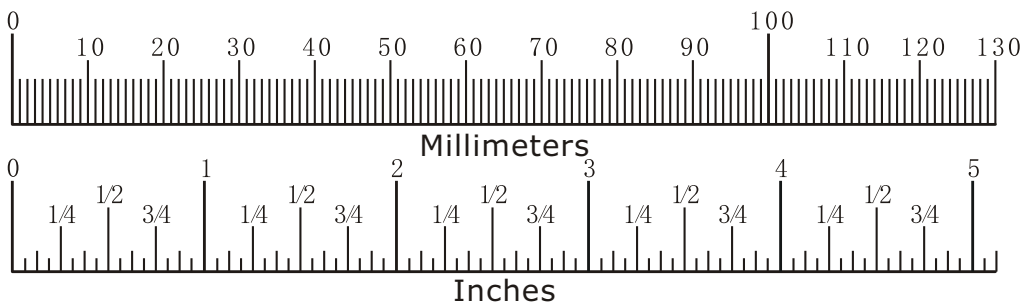

Diameter of bolt (mm/inch)	M6(1/4")	M8(5/16")	M10(3/8")	M12(1/2")	M16(5/8")
Tightening torque (N.m)	9~12	22~30	45~59	78~104	193~257
Operational methods for adult men	The strength of the wrist	The strength of the wrist and forearm	The strength of the entire arm	The strength of the arm and upper body	with all strength

Assembly Instructions

Assembly of the equipment takes professional installers about 2 hours. If this is the first time you have assembled this type of equipment, plan to spend more time. It is strongly recommended to assemble the equipment by professional installers. You may find it quicker, safer, easier to assemble this equipment with the help of a friend, as some of components may be large, heavy or awkward to handle alone. It is important that you assemble your product in a clean, clear, uncluttered area. This will enable you to move around the product while you are fitting components and reduce the possibility of injury during assembly.

NOTE

As with any assembled part, proper alignment and adjustment is critical. While tightening the fasteners, be sure to leave room for adjustments. Do not fully tighten the fasteners until instructed to do so. Be careful to assemble the components in the sequence presented in this guide.

Assembly

STEP 1

The Left Bottom Frame Assembly (#1), Right Bottom Frame Assembly (#2), one piece of Upper Beam Frame (#5) and Before Connecting Frame (#7) connected together using:

- eight M12*135 SHCS (#36)
- sixteen $\Phi 13*\Phi 24*2.5$ Flat Washers (#50)
- eight M12 Nylon Lock Nuts (#48)

Note: Hand tighten bolts and Nylon Lock nuts until machine is fully assembled.

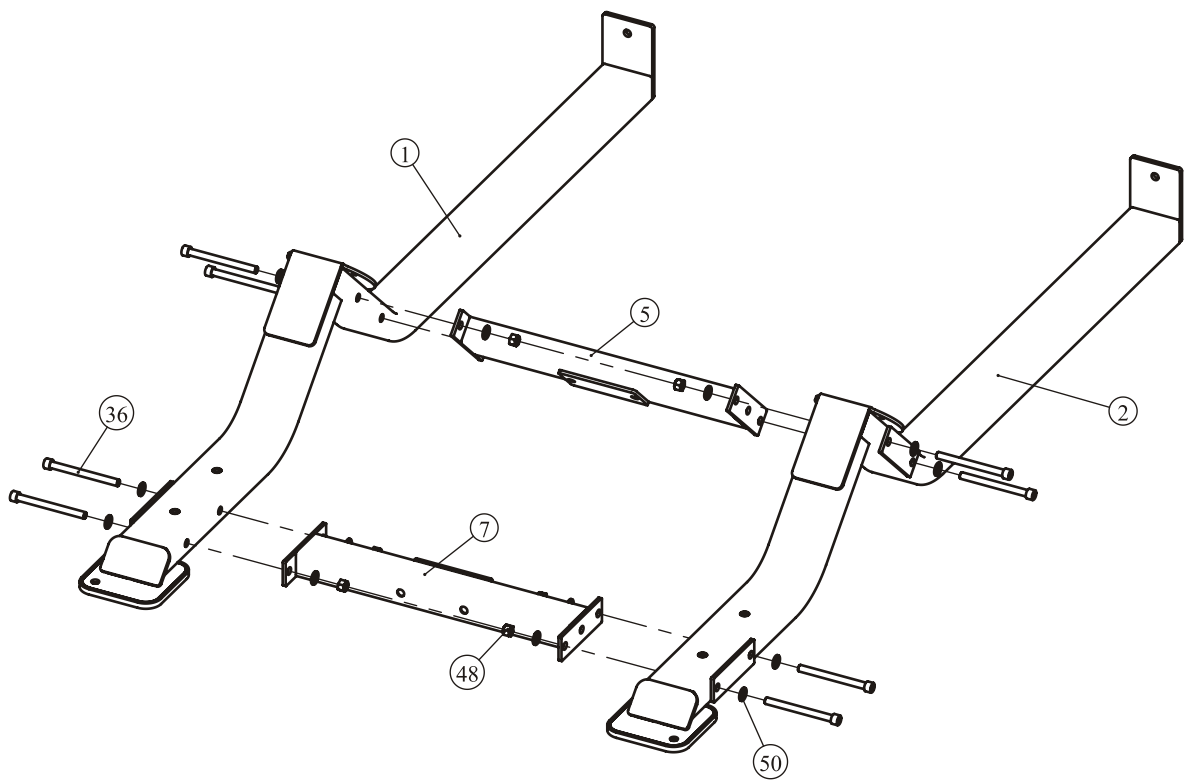

Assembly

STEP 2

1. Two pieces of Lead Rail (#21) and Left Bottom Frame Assembly (#1), Right Bottom Frame Assembly (#2) connected together using:

- six M10*20 FHCS (#46)

2. Two Large Rubber Bumper (#27), Left Idler Wheel Frame Assembly (#23), Right Idler Wheel Frame Assembly (#24) Wear into the two pieces of Lead Rail (#21).

Note: Two people will be needed to complete this step safely.

Hand tighten bolts and Nylon Lock nuts until machine is fully assembled.

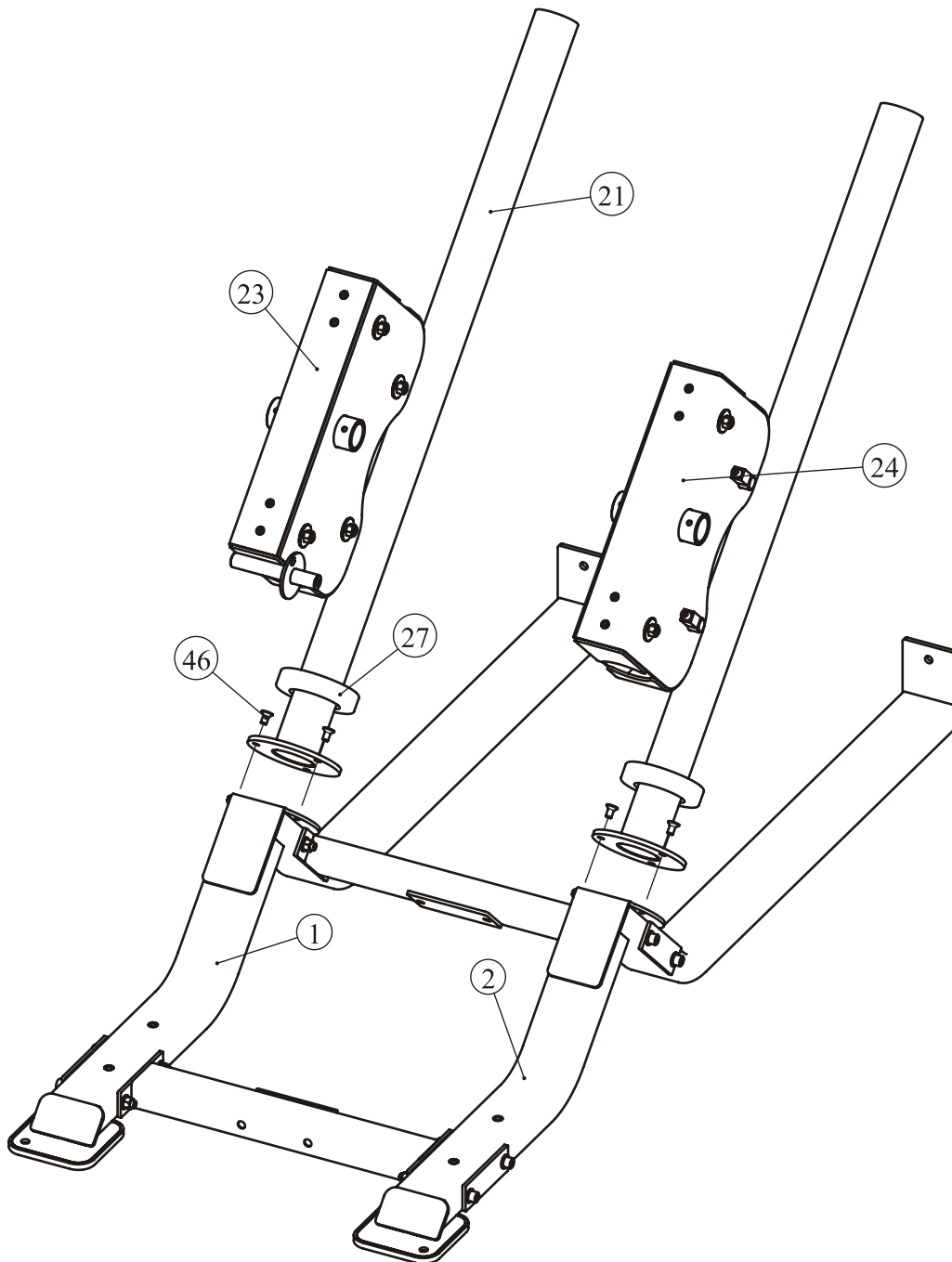

Assembly

STEP 3

1. The Left Union Frame Assembly (#3), Right Union Frame Assembly (#4) and Left Bottom Frame Assembly (#1), Right Bottom Frame Assembly (#2), Lead Rail (#21) connected together using:

- two M16*100 SHCS (#35)
- four M12*85 SHCS (#38)
- two $\Phi 28*\Phi 16.5*2$ Flat Washers (#49)
- six $\Phi 13*\Phi 24*2.5$ Flat Washers (#50)
- two M12 Nylon Lock Nuts (#48)

2. The Left Union Frame Assembly (#3), Right Union Frame Assembly (#4) and Lower Beam Frame (#6), four pieces of Weight Plate Storage (#30) connected together using:

- eight M12*135 SHCS (#36)
- sixteen $\Phi 13*\Phi 24*2.5$ Flat Washers (#50)
- eight M12 Nylon Lock Nuts (#48)

Note: Hand tighten bolts and Nylon Lock nuts until machine is fully assembled.

STEP 4

The Middle Connection Frame assembly (#15) and two pieces of Upper Beam Frame (#5) connected together, then one pieces of Upper Beam Frame (#5) and Left Union Frame Assembly (#3), Right Union Frame Assembly (#4) connected together using:

- four M12*135 SHCS (#36)
- four M12*85 SHCS (#38)
- sixteen $\Phi 13*\Phi 24*2.5$ Flat Washers (#50)
- eight M12 Nylon Lock Nuts (#48)

Note: Two people will be needed to complete this step safely.

Hand tighten bolts and Nylon Lock nuts until machine is fully assembled.

Assembly

STEP 3

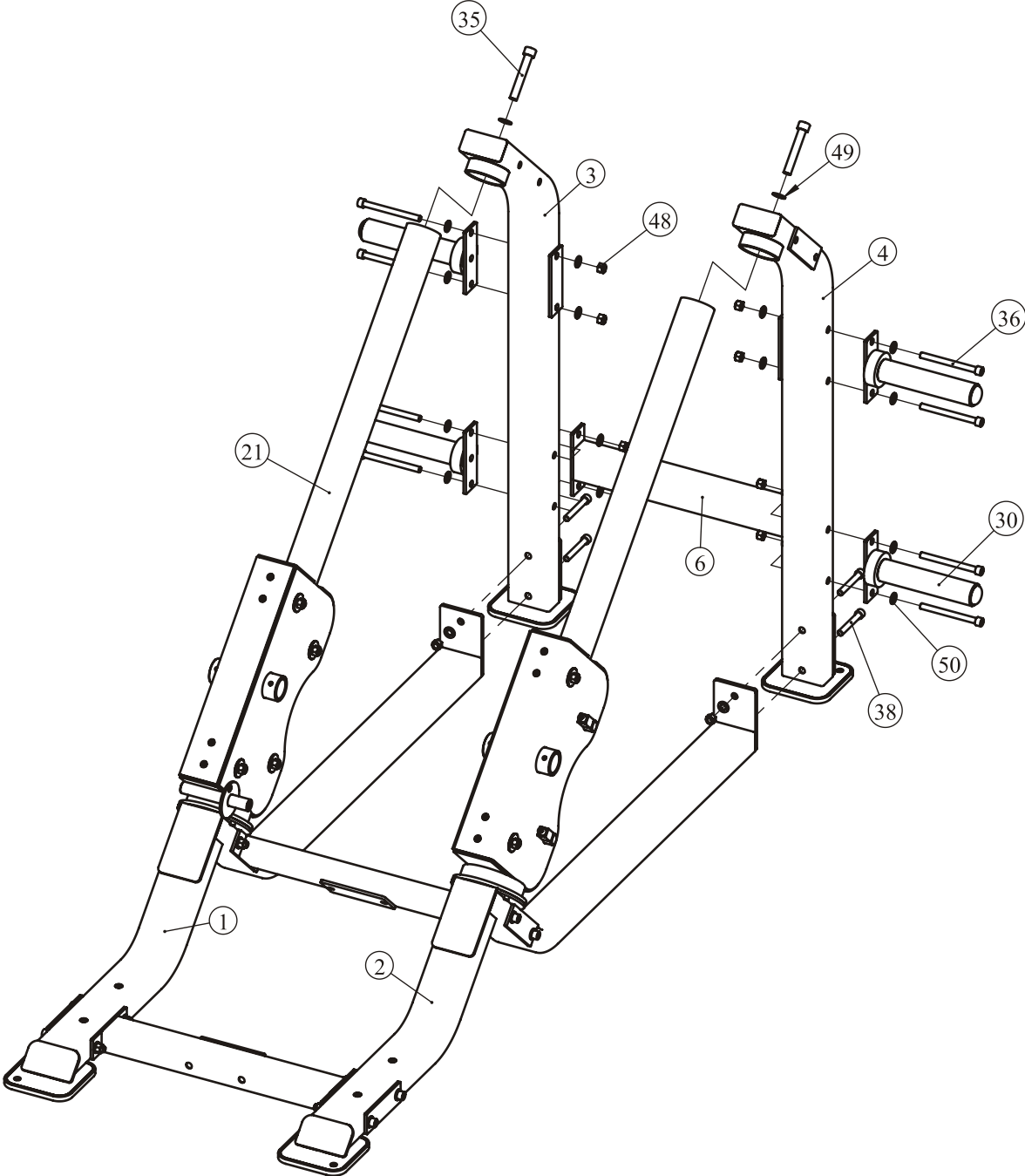

Assembly

STEP 4

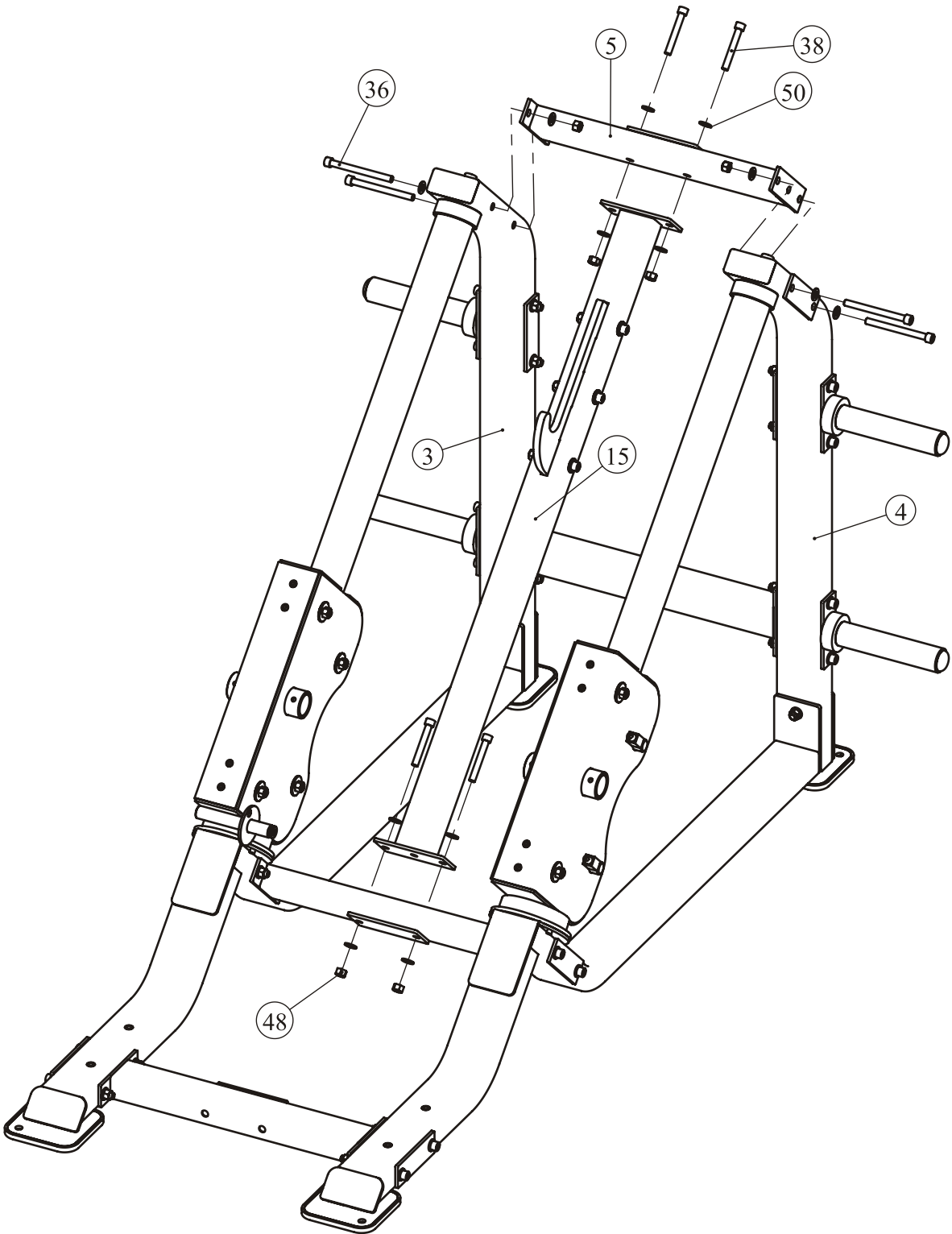

Assembly

STEP 5

1. The Left Extend Frame Assembly (#18), Right Extend Frame Assembly (#19) and Limit Shaft $\Phi 35$ (#26) connected together.
2. The Left Extend Frame Assembly (#18) and Link Frame Assembly (#16), Adjustable Handle Frame Assembly (#17) connected together. Using:
 - two M12*70 SHCS (#40)
 - four $\Phi 13*\Phi 24*2.5$ Flat Washers (#50)
 - two M12 Nylon Lock Nuts (#48)

Note: Hand tighten bolts and Nylon Lock nuts until machine is fully assembled.

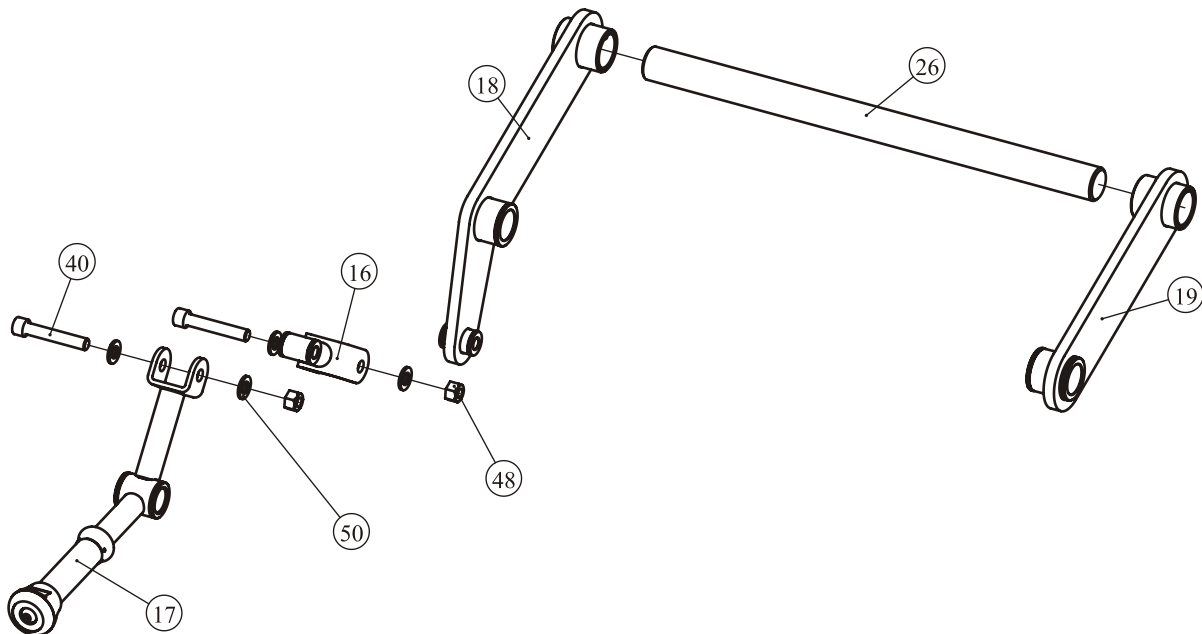

Assembly

STEP 6

1. Two pieces of Weight Horn assembly (#22) and Left Idler Wheel Frame Assembly (#23), Right Idler Wheel Frame Assembly (#24) connected together using:

- two M10*8 Socket Set Screw (#47)
- two M10*30 SHCS (#58)
- two $\Phi 10$ Split Lock Washer (#59)
- two $\Phi 11*\Phi 20*2$ Flat Washers (#51)

2. The Left Extend Frame Assembly (#18), Right Extend Frame Assembly (#19) and Left Idler Wheel Frame Assembly (#23), Right Idler Wheel Frame Assembly (#24), Small Limit frame Assembly (#25) connected together using:

- three M12*30 SHCS (#41)
- two $\Phi 50.8*\Phi 13.5*3$ Flat Washers (#34)
- two $\Phi 12$ Split Lock Washer (#52)
- one $\Phi 13*\Phi 24*2.5$ Flat Washers (#50)

3. The Limit shaft $\Phi 35$ (#26) and Left Extend Frame Assembly (#18), Right Extend Frame Assembly (#19) connected together using:

- two M10*20 SHCS (#44)

NOTE: Attention the angle of Weight Horn Assembly (#22) as shown.

Tighten all the hardware.

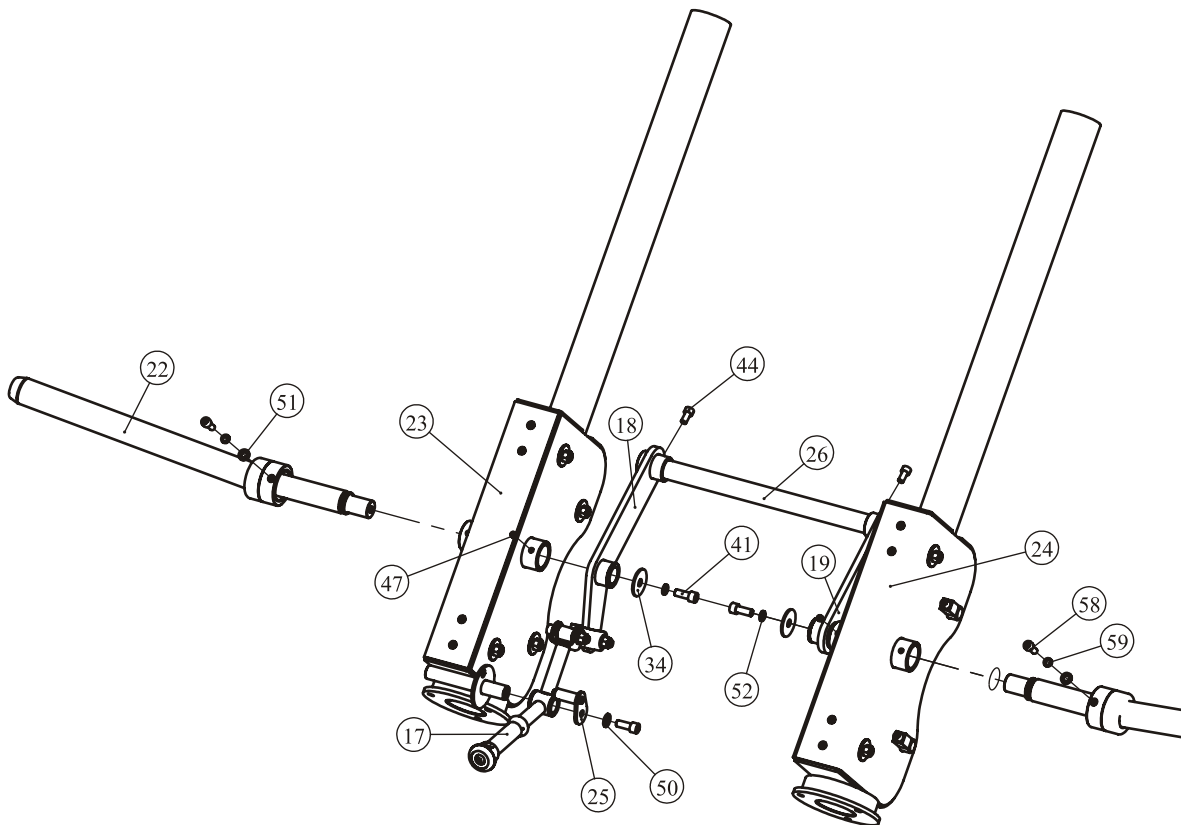

Assembly

STEP 7

1. The Connection Frame Assembly (#20) and Left Idler Wheel Frame Assembly (#23), Right Idler Wheel Frame Assembly (#24) connected together. Using:

- eight M12*30 SHCS (#41)
- eight $\Phi 13*\Phi 24*2.5$ Flat Washers (#50)

2. The Arm Pad Frame Assembly (#12) and Connection Frame Assembly (#20) connected together. Using:

- four M12*75 SHCS (#39)
- eight $\Phi 13*\Phi 24*2.5$ Flat Washers (#50)
- four M12 Nylon Lock Nuts (#48)

3. The Left Handle Assembly (#13), Right Handle Assembly (#14) and Arm Pad Frame Assembly (#12) connected together. Using:

- two M12*135 SHCS (#36)
- four $\Phi 13*\Phi 24*2.5$ Flat Washers (#50)
- two M12 Nylon Lock Nuts (#48)

Note: Hand tighten bolts and Nylon Lock nuts until machine is fully assembled.

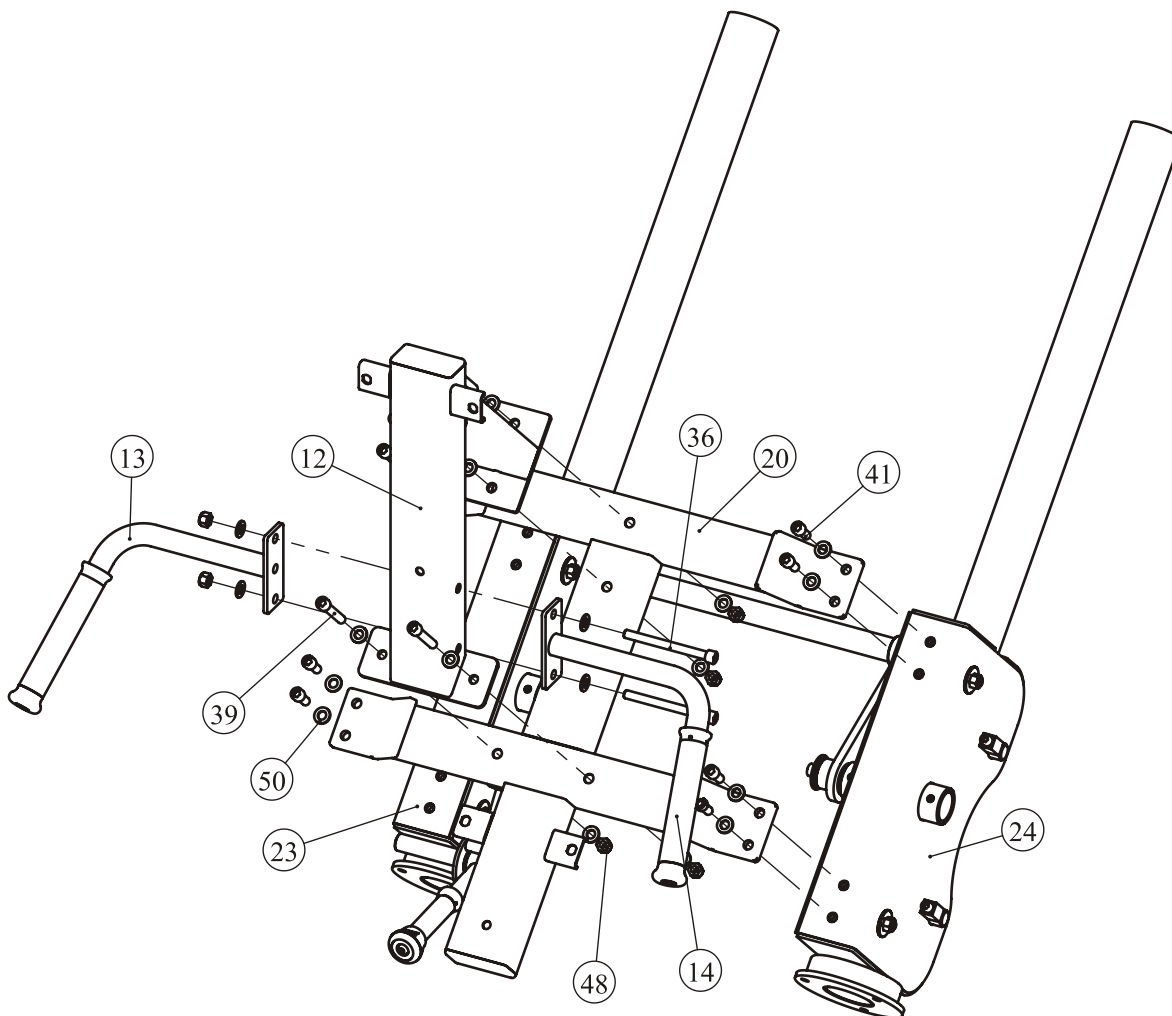

Assembly

STEP 8

1. The Arm Pad (#28) and Arm Pad Frame Assembly (#12) connected together using:

- two M10*25 SHCS (#43)
- one M10*75 SHCS (#42)
- three $\Phi 11*\Phi 20*2$ Flat Washers (#51)

2. The Seat Pad (#29) and Connection Frame Assembly (#20) connected together using:

- two M10*25 SHCS (#43)
- one M10*75 SHCS (#42)
- three $\Phi 11*\Phi 20*2$ Flat Washers (#51)

Note: Hand tighten bolts and Nylon Lock nuts until machine is fully assembled.

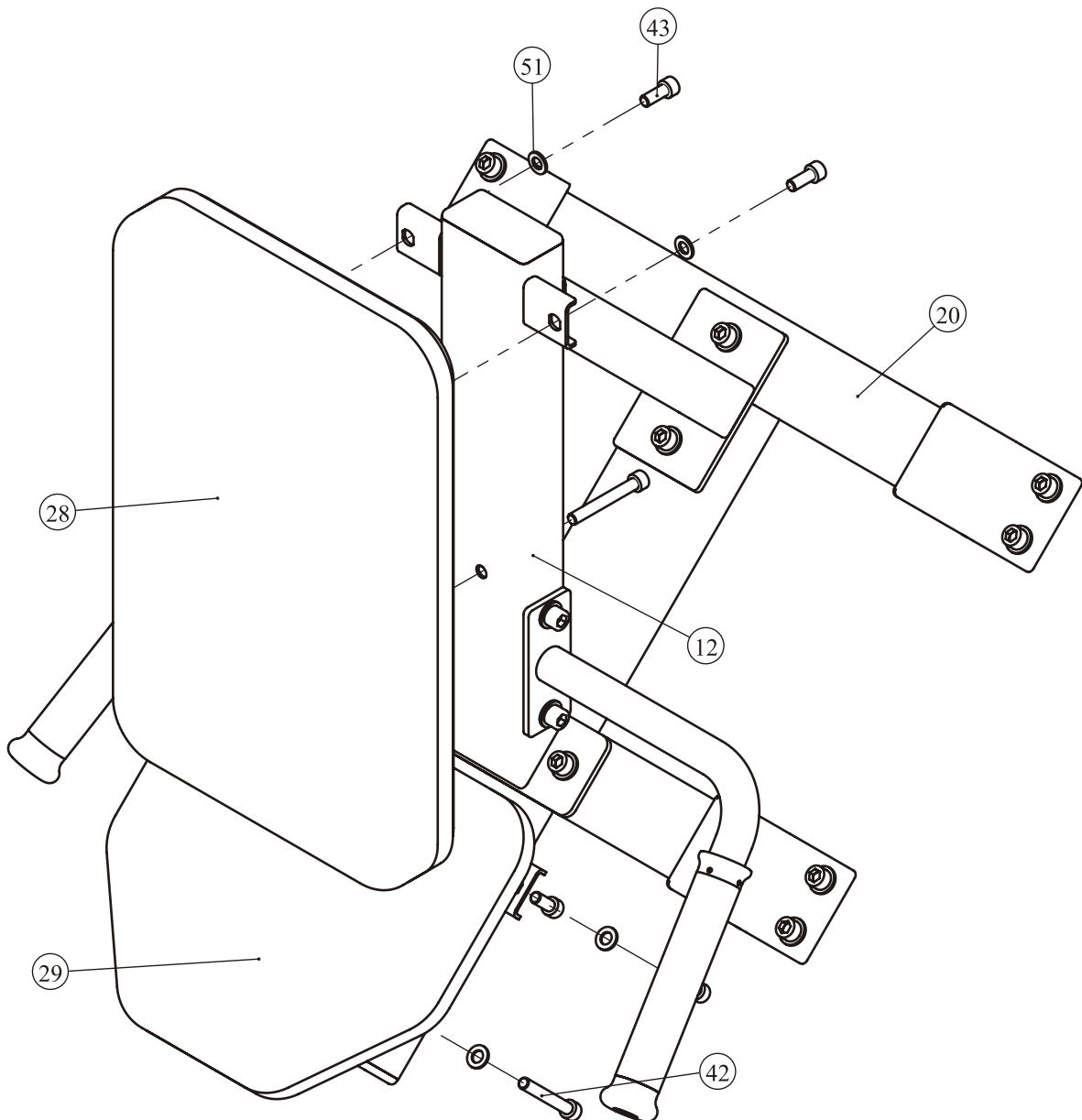

Assembly

STEP 9

1. The Pedal Bracket (#8), Affixed Frame (#31) and Before Connecting Frame (#7) connected together using:

- two M12*110 SHCS (#37)
- four $\Phi 13*\Phi 24*2.5$ Flat Washers (#50)
- two M12 Nylon Lock Nuts (#48)

2. The Left Foot Frame (#9), Right Foot Frame (#10) and External Fixation Plate (#32), Left Bottom Frame Assembly (#1), Right Bottom Frame Assembly (#2) connected together using:

- two M12*85 SHCS (#38)
- four M12*30 SHCS (#41)
- eight $\Phi 13*\Phi 24*2.5$ Flat Washers (#50)
- two M12 Nylon Lock Nuts (#48)

Note: Hand tighten bolts and Nylon Lock nuts until machine is fully assembled.

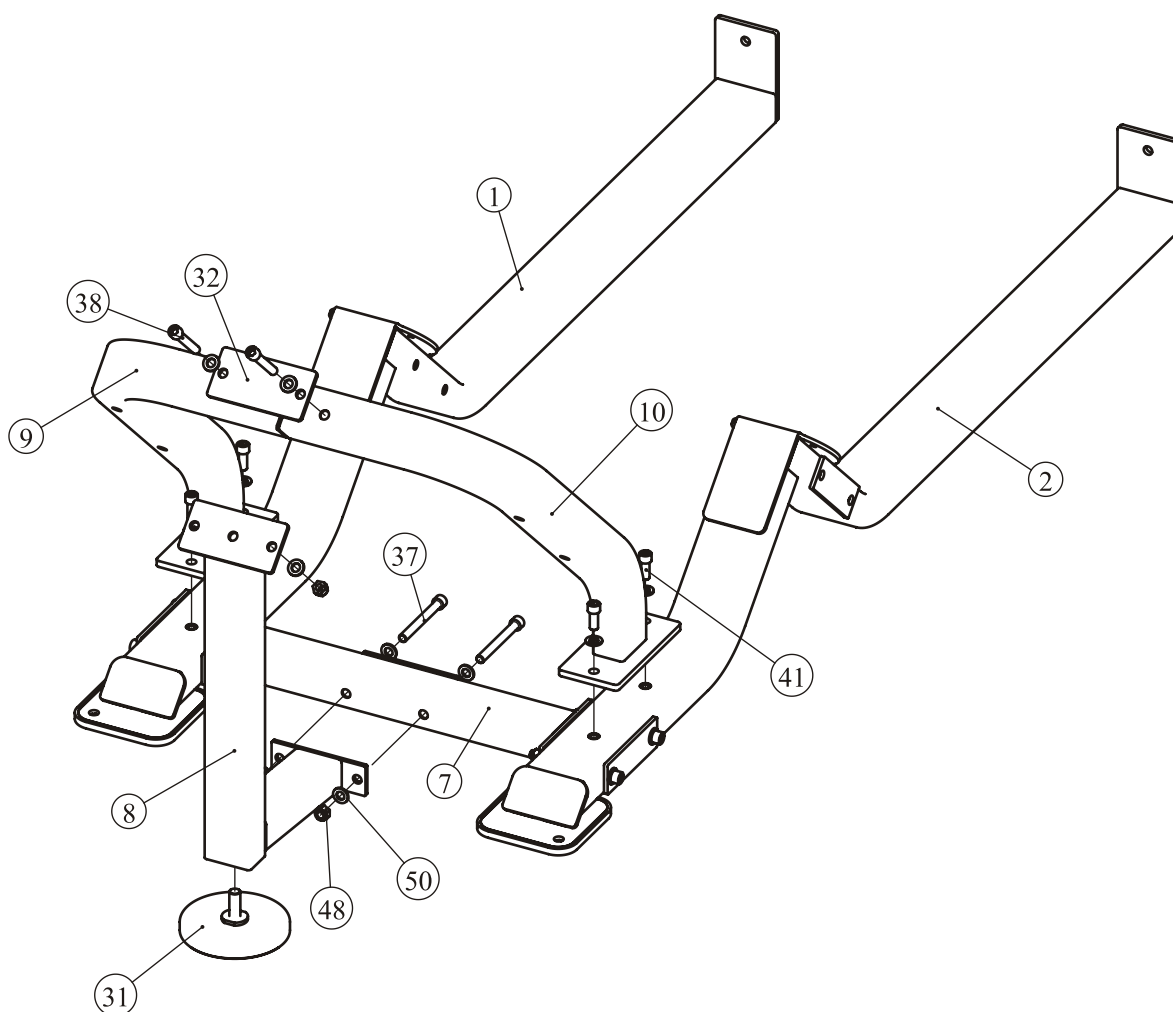

Assembly

STEP 10

The Foot Checkered (#11), and Left Foot Frame (#9), Right Foot Frame (#10) connected together. Using:

- four M12*100 FHCS (#45)
- four $\Phi 13*\Phi 24*2.5$ Flat Washers (#50)
- four M12 Nylon Lock Nuts (#48)

Note: Tighten all bolts and nuts before continuing.

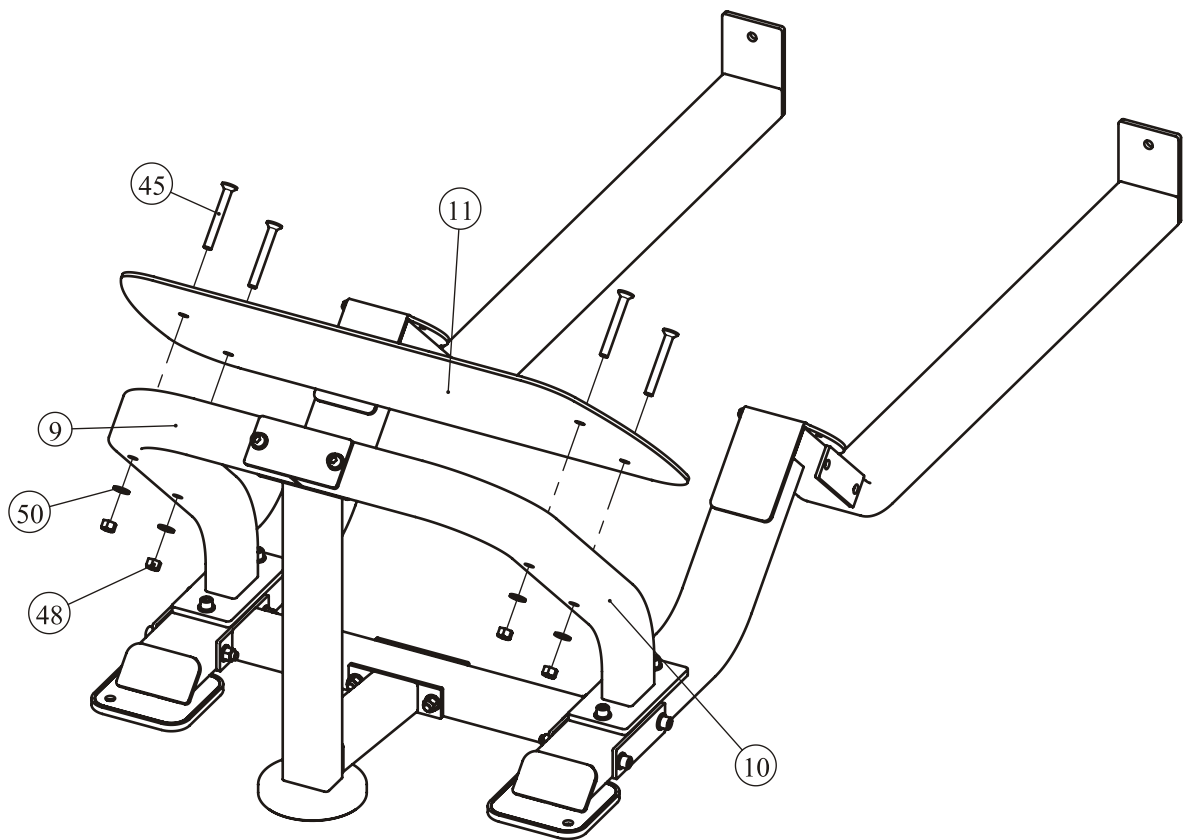

Adjust Instructions

Weight Plate Installation Requirements

1. Please use Olympic Weight Plate which hole is greater than $\Phi 50\text{mm}$ and external diameter is less than $\Phi 500\text{mm}$.
2. The total weight of one side can not be greater than 150kg.
3. This equipment does not contains Weight Plate.

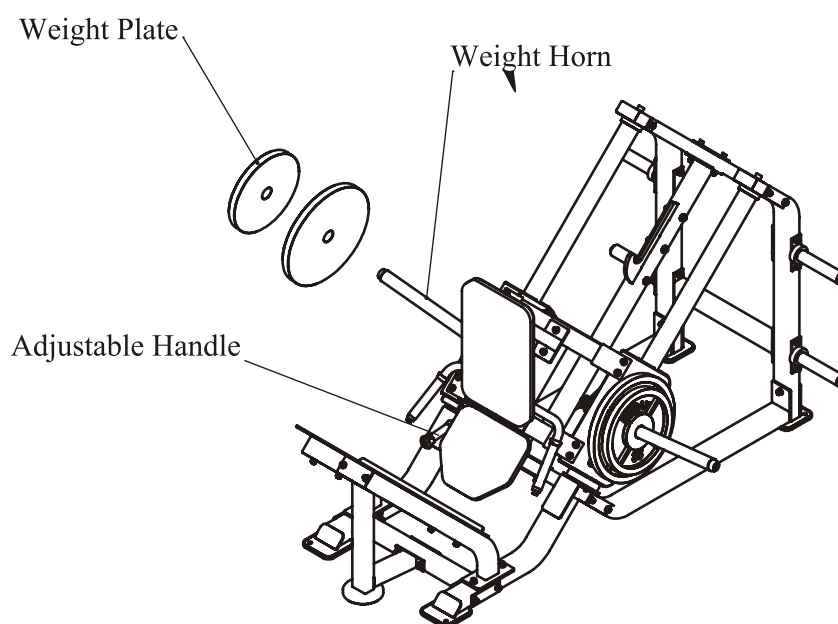

Wheel Adjustment

1. Adjust the Adjust Screws with Hex Key so that Wheels can be close to Guide Rails.
2. Tighten the Nylon Nuts.

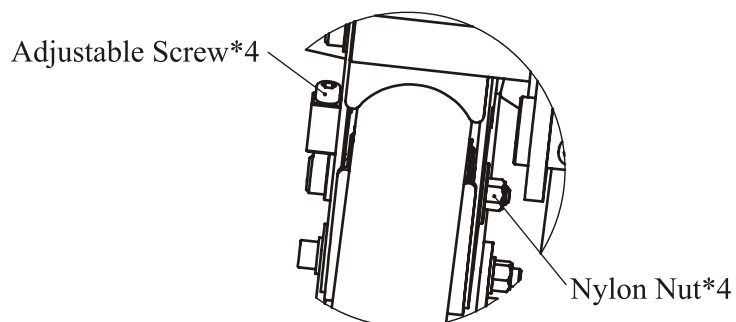

Exercise Instructions

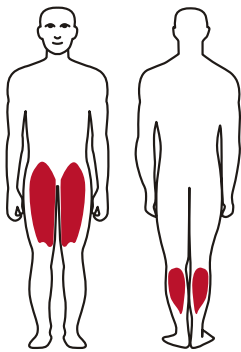
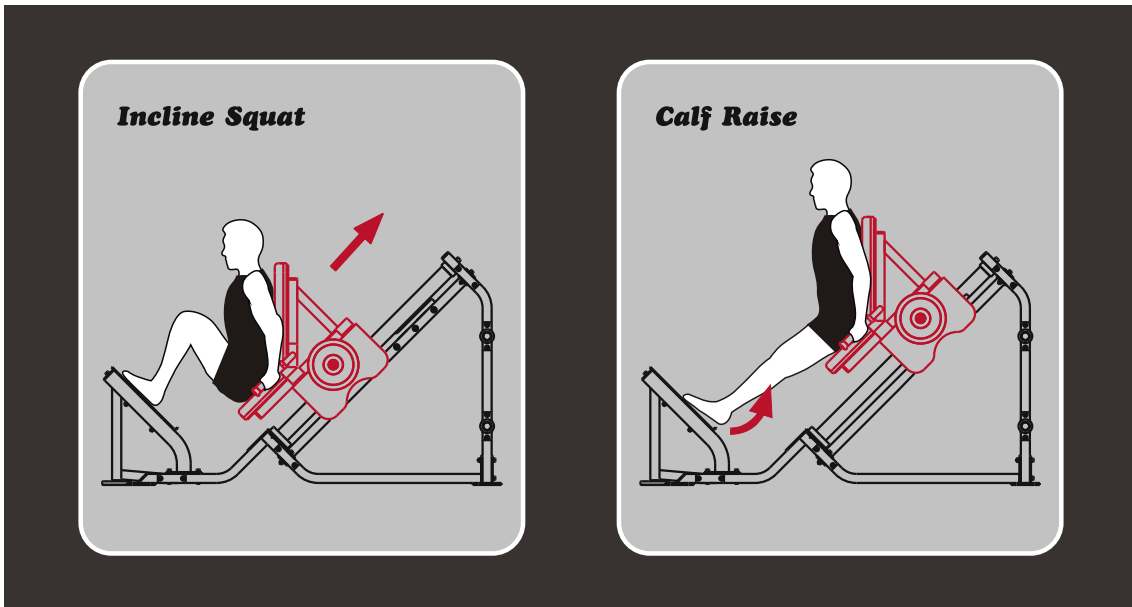

Exercise Instructions

1. Select an appropriate weight.
2. Seated and push Back Pad backward until legs straight then push the Adjustable Handle.
3. Pause slightly then squat down to the appropriate position slowly.
4. Before finished, pull Adjustable Handle back while legs straight.

Maintenance Schedule

ROUTINE	COMMERCIAL MAINTENANCE	HOME MAINTENANCE	LATEST DATE ENTRY						
Inspect; Links, Pull Pins, Snap Locks, Swivels, Weight Stack Pins	DAILY	WEEKLY							
Clean; Upholstery	DAILY	WEEKLY							
Inspect; Cables or Belts and their tension	DAILY	WEEKLY							
Inspect; Accessory Bars, and Handles	WEEKLY	3 MONTHS							
Inspect; All Decals	WEEKLY	3 MONTHS							
Inspect; All Nuts and Bolts, Tighten if needed	WEEKLY	3 MONTHS							
Inspect; Anti-Skid Surface	WEEKLY	3 MONTHS							
Clean & Lubricate; Guide Rods with a Teflon (PTFE) based lubricant (Superlube)	MONTHLY	3 MONTHS							
Lubricate; Seat Sleeves, Turcite Bushings, Linear Bearing	MONTHLY	3 MONTHS							
Clean and Wax; All Glossy Finishes	6 MONTHS	YEARLY							
Repack with Grease; Linear Bearings	6 MONTHS	YEARLY							
Replace; Cables, Belts and Connecting Parts	YEARLY	3 YEARS							

Your equipment comes with a commercial maintenance decal. For personal, in home use, please follow the home maintenance schedule listed above.

General Maintenance Information

Links, Pull-Pins, Snap Hooks, Swivels, Weight Stack Pins:

- * Check all pieces for signs of visible wear or damage.
- * Check springs in snap hooks and pull-pins for proper tension and alignment.
- * If the spring sticks or has lost its rigidity, replace it immediately.

Upholstery:

- * To ensure prolonged upholstery life and proper hygiene, all upholstered pads should be wiped down with a damp cloth after every workout.
- * Periodically take the time to use a mild soap or an approved vinyl upholstery cleaner to deter the onset of cracking or drying. Avoid using any abrasive cleaners or cleaners not intended for use on vinyl.
- * Replace ripped or worn upholstery immediately.
- * Keep sharp or pointed objects clear of all upholstery.

Decals:

- * Inspect and familiarize yourself with any safety warnings or other user information posted on each decal.

Nuts and Bolts:

- * Inspect all nuts and bolts for any loosening and tighten if needed.
- * Go through a re-tightening sequence periodically to ensure that all hardware is tensioned proper.

Anti-Skid Surfaces:

- * These surfaces are designed to supply secure footing and need to be replaced if they appear worn or become slippery.

Belts and Cables:

- * We use only high quality belt, and mil-spec cables.
- * Visually inspect the belts and cables for fraying, cracking, peeling or discoloration.
- * While the machine is not in use, carefully run your fingers along the belt or cable to feel for thinning or bulging areas.
- * Replace belts and cables immediately at the first signs of damage or wear. Do not use equipment until belts or cables have been replaced.

Belt and Cable Tension:

- * Referring to the Owners Manual, when belts or cables are used check all bolts attachments to be sure they are properly attached.
- * Check slack in cables and re-adjust cable tension if needed.

Seat Sleeves, Guide Rods:

- * Wipe down adjusting tubes with a dust free rag before applying lubricant.
- * Lubricate seat sleeves and Guide Rods with a Silicon or Teflon based lubricant spray.

Linear Bearings:

- * Referring to the Owners Manual carefully disassemble the bearing from its housing and place a finger full of light grease (lithium, super lube, etc.) into the inside of the bearing. Using your finger, press the grease into the ball-bearings and their tracks. repeat until the ball-bearing tracks are full of grease. Insert the shaft back into the bearing and wipe off excess grease.

PLEASE KEEP THIS FOR YOUR RECORDS

Weight Training Tips

Use this manual to guide you through the basic exercises you can perform on your equipment. To gain maximum results and avoid possible injury, consult a fitness professional to develop your complete exercise program.

Always consult your physician before starting any exercise program.

To be successful in your exercise program, it is important to develop an understanding of the basic principles of strength training. Now that you have your equipment, it is only natural that you want to get started immediately. First, determine a set of realistic goals and objectives for yourself. By deciding on an exercise plan that is right for you prior to starting, you will contribute significantly to your success.

Warm up properly before engaging in weight resistance training. Stretching, yoga, jogging, calisthenics or other cardiovascular exercise can help prepare your body for the heavier workload of lifting weights.

Learn how to perform the exercise correctly before using heavy weight. Correct form is important to avoid injury and to ensure that you work the proper muscle groups.

Know your limitations. If you are new to weight training or are embarking on an exercise regimen after a long layoff, start slowly and build foundational strength over a longer period of time.

Pay attention to your breathing. Exhale when you exert is a general rule of thumb. Never hold your breath.

